



## User Guide

SC2-PRESTO • *CompactPCI*<sup>®</sup> Serial CPU Card  
4<sup>th</sup> Generation Intel<sup>®</sup> Core<sup>™</sup> Processor (Haswell)

Document No. 7605 • Edition 42 • 15 February 2018



## Contents

About this Manual	5
Edition History	5
Related Documents	7
Nomenclature	7
Trade Marks	7
Legal Disclaimer - Liability Exclusion	7
Standards	8
Overview	9
Technical Features	11
Feature Summary	11
Power Requirements	16
Block Diagram	17
Top View Component Assembly	18
Bottom View Component Assembly	19
Front Panel Connectors	20
Front Panel Switches & Indicators	20
On-Board Connectors & Sockets	21
Pin Headers	21
Jumpers	21
Microprocessor	22
Thermal Considerations	23
Main Memory	24
Graphics Subsystem	26
LAN Subsystem	27
Serial ATA Interface (SATA)	28
PCI Express® Interface	29
Universal Serial Bus (USB)	30
Utility Interfaces	31
Real-Time Clock	32
SPI Flash	33
Reset	34
Watchdog	36
Front Panel LEDs	37
PG (Power Good) LED	38
GP (General Purpose) LED	38
HD (Hard Disk Activity) LED	38
EB (Ethernet Backplane) LED	39
Main Power Supply Control (PS_ON#)	39
Power Supply Status (PWR_FAIL#)	39
Mezzanine Side Board Options	40

CompactPCI® Serial	47
System Slot Controller	47
Peripheral Slot Operation	50
Board Hot-Plug	50
Installing and Replacing Components	55
Before You Begin	55
Installing the Board	56
Removing the Board	57
EMC Recommendations	58
Replacement of the Battery	59
Technical Reference	60
Local PCI Devices	60
Local SMB Devices	61
Hardware Monitor LM87	62
Board Control and Status Registers (BCSR)	63
Write/Read Control Register 0	64
Read/Clear Status Register 0	65
Read/Clear Status Register 1	66
Read PLD Revision Register	66
GPIO Usage	67
GPIO Usage QM87 PCH	67
Configuration Jumpers	69
Configuration PCI Express Switch (DS-P)	69
Loading UEFI BIOS Setup Defaults/IEEE 1588 Pulse per Second (J-GP)	70
Manufacturer Mode Jumper (J-MFG)	71
RTC Reset (J-RTC)	71
Connectors	72
Front Panel Connectors	72
DisplayPort Connectors	75
Screw Locking Option for mDP Connectors	76
VGA Video Connector	79
USB Connectors	80
Ethernet Connectors	81
Mezzanine Connectors	82
Expansion Interface P-EXP	84
High Speed Expansion Connector P-HSE	85
PCI Express® Expansion Header P-PCIE	88
DisplayPort Expansion Header P-DP3	89
Pin Headers & Debug	90
Front Panel Handle Microswitch Header P-FPH	90
PLD Programming Header P-ISP	90

Processor Debug Header P-XDP .....	91
Backplane Connectors .....	92
CompactPCI® Serial Backplane Connector P1 .....	93
CompactPCI® Serial Backplane Connector P2 .....	94
CompactPCI® Serial Backplane Connector P3 .....	95
CompactPCI® Serial Backplane Connector P4 .....	96
CompactPCI® Serial Backplane Connector P5 .....	97
CompactPCI® Serial Backplane Connector P6 .....	98
Appendix .....	99
Known Issues .....	99
Mechanical Drawing .....	100

## About this Manual

This manual describes the technical aspects of the SC2-PRESTO, required for installation and system integration. It is intended for the experienced user only.

## Edition History

Ed.	Contents/ <i>Changes</i>	Author	Date
1	User Manual SC2-PRESTO, english, preliminary edition Text #7605, File: sc2_ug.wpd	gn	2014-07-25
2	Added Specs to i7-4700EQ in table "Intel Core Processors Supported" Removed entries from table "Recommended Accessories" Added Section "Board Control and Status Registers"	gn	2014-08-07
3	Edited table "High Speed Expansion Connector P-HSE"	gn	2014-09-02
4	Updated description of BCSR Status Register 1	gn	2014-10-02
5	Photos added/changed	jj	15 October 2014
6	Photos added/changed	jj	20 October 2014
7	Photos added/changed	jj	22 October 2014
8	Modified block diagram (Trusted Platform Module TPM 2.0 added, as from PCB revision 1.0 off)	jj	4 November 2014
9	Updated table 'Feature Summary'	jj	18 November 2014
10	Additions to section "CompactPCI Serial"	gn	2014-11-19
11	Modified illustration 'Backplane Resources', modified illustration 'Block Diagram'	jj	16 December 2014
12	Added notes to the QM87 SATA channel speed capabilities	gn	2014-12-17
13	Clarified resetting of UEFI BIOS settings to factory defaults	gn	2015-01-16
14	Table 'Feature Summary' added TDP for i7-4700EQ Processor 2.4GHz = 47W	jj	20 January 2015
15	Added comment to PCIe polarity inversion on tables "P1 CompactPCI Serial Connector" and "P2 CompactPCI Serial Connector"	gn	2015-01-26
16	Added illustration backplane resources system slot right aligned	jj	19 February 2015
17	Added photos SC2 w. SCS side card, added illustration F/P options 8HP/12HP	jj	25 February 2015
18	Updated description of BCSR Control Register 0	gn	2015-02-26
19	Modified illustration 'Mezzanine Side Card Connectors' (SC2-PRESTO connector PCIE is configurable as PCIe 4x1 or 1x4)	jj	3 March 2015
20	Updated description of BCSR Status Registers 0 and 1	gn	2015-04-01
21	Cleaned up section "Watchdog"	gn	2015-04-07
22	Added IEEE1588 PTP Feature Updated "GPIO Usage QM87 PCH"	gn	2015-05-18

Ed.	Contents/ <i>Changes</i>	Author	Date
23	Added photo C48-M2 mezzanine storage module	jj	21 May 2015
24	Added MTBF, added more photos w. C48-M2 mezzanine storage module	jj	27 May 2015
25	Updated LM87 Information, added some Power Requirements, updated Operating Temperature	gn	2015-05-28
26	Added photo SC2 with SCS side card M.2 SATA SSDs populated	jj	2 June 2015
27	Changed photo SC2 in SRS-BLUBOXX	jj	19 June 2015
28	Added section "Known Problems"	gn	2015-07-02
29	Table 'Feature Summary' BIOS replaced by Firmware (UEFI) Table 'Reference Documents' UEFI & ACPI specifications	cr/jj	13 August 2015
30	Table 'Feature Summary' updated list of processors, TPM 2.0 module populated by default (was option), Secure Boot & Measured Boot supported	cr/gn/jj	15/16 September 2015
31	Corrections in table of section "Hardware Monitor LM87" Corrections in table "GPIO Usage QM87 PCH"	gn	2015-09-29
32	Table 'Feature Summary' added RT OS support	jj	30 September 2015
33	Table 'Feature Summary' fixed OpenGL from 3.2 to 4.3	jj	26 October 2015
34	Table 'Feature Summary' added section 'Performance Rating'	jj	30 October 2015
35	Renamed and updated section "Known Issues"	gn	2016-07-07
36	Marked backplane connector P1 pin G3 (SATA_SDI) as "not connected"	gn	2016-08-05
37	Screw locking options for mDP connectors	jj	9 December 2016
38	Added photo USB cable connector fixation	jj	19 June 2017
39	Updated section "Hardware Monitor LM87"	gn	2017-08-01
40	Added photo which shows battery holder option	jj	9 August 2017
41	Added Intel® AMT support to table 'Feature Summary'	jj	8 November 2017
42	Added description of the PCI Express® numbering scheme for the PEX 8618 PCIe switch to assigned backplane slots (chapter Local PCI Devices)	jj	15 February 2018

## Related Documents

Related Information SC2-PRESTO	
SC2-PRESTO Home	<a href="http://www.ekf.com/s/sc2/sc2.html">www.ekf.com/s/sc2/sc2.html</a>
SC2-PRESTO Product Information	<a href="http://www.ekf.com/s/sc2/sc2_pi.pdf">www.ekf.com/s/sc2/sc2_pi.pdf</a>

## Nomenclature

Signal names used herein with an attached '#' designate active low lines.

## Trade Marks

Some terms used herein are property of their respective owners, e.g.

- ▶ Shark Bay, Haswell, Lynx Point, Core i7: ® Intel
- ▶ CompactPCI, CompactPCI PlusIO, CompactPCI Serial: ® PICMG
- ▶ Windows: ® Microsoft
- ▶ EKF, ekf system: ® EKF

EKF does not claim this list to be complete.

## Legal Disclaimer - Liability Exclusion

This manual has been edited as carefully as possible. We apologize for any potential mistake. Information provided herein is designated exclusively to the proficient user (system integrator, engineer). EKF can accept no responsibility for any damage caused by the use of this manual.

## Standards

Reference Documents		
Term	Document	Origin
CFast™	CFast™ Specification Rev. 1.0	<a href="http://www.compactflash.org">www.compactflash.org</a>
CompactPCI®	CompactPCI Specification, PICMG® 2.0 R3.0, Oct. 1, 1999	<a href="http://www.picmg.org">www.picmg.org</a>
CompactPCI® PlusIO	CompactPCI PlusIO Specification, PICMG® 2.30 R1.0, November 11, 2009	<a href="http://www.picmg.org">www.picmg.org</a>
CompactPCI® Serial	CompactPCI Serial Specification, PICMG® CPCI-S.0 R1.0, March 2, 2011	<a href="http://www.picmg.org">www.picmg.org</a>
DisplayPort	VESA DisplayPort Standard Version 1.2 December 22, 2009 VESA Mini DisplayPort Connector Standard Version 1 October 26, 2009	<a href="http://www.vesa.org">www.vesa.org</a>
DVI	Digital Visual Interface Rev. 1.0 Digital Display Working Group	<a href="http://www.ddwg.org">www.ddwg.org</a>
Ethernet	IEEE Std 802.3, 2000 Edition	<a href="http://standards.ieee.org">standards.ieee.org</a>
Precision Time Protocol	IEEE Std 1588-2008, July 24, 2008	<a href="http://standards.ieee.org">standards.ieee.org</a>
LPC	Low Pin Count Interface Specification, Revision 1.1	<a href="http://developer.intel.com/design/chipsets/industry/lpc.htm">developer.intel.com/design/chipsets/industry/lpc.htm</a>
HD Audio	High Definition Audio Specification Rev.1.0	<a href="http://www.intel.com/design/chipsets/hdaudio.htm">www.intel.com/design/chipsets/hdaudio.htm</a>
PCI Express®	PCI Express® Base Specification 3.0	<a href="http://www.pcisig.com">www.pcisig.com</a>
SATA	Serial ATA 2.5/2.6 Specification Serial ATA 3.0 & 3.1 Specification	<a href="http://www.sata-io.org">www.sata-io.org</a>
TPM	Trusted Platform Module 2.0	<a href="http://www.trustedcomputinggroup.org">www.trustedcomputinggroup.org</a>
UEFI	Unified Extensible Firmware Interface UEFI Specification Version 2.5 ACPI Specification Version 6.0	<a href="http://www.uefi.org">www.uefi.org</a>
USB	Universal Serial Bus 3.0 Specification, Revision 1.0 November 12, 2008	<a href="http://www.usb.org">www.usb.org</a>



## Overview

*The SC2-PRESTO is a rich featured high performance 4HP/3U CompactPCI® Serial CPU board, equipped with a 4<sup>th</sup> generation Intel® Core™ mobile processor (Haswell dual- or quad-core). The SC2-PRESTO front panel is provided with two Gigabit Ethernet jacks, two USB 3.0 receptacles, and two mDP connectors, compliant with the DisplayPort 1.2 standard for Multi-Stream-Transport (MST). Local expansion mezzanine cards are available for additional I/O.*

While mechanically compliant to *CompactPCI® Classic*, *CompactPCI® Serial* (PICMG® CPCIS.0) defines a completely new card slot, based on PCI Express®, SATA, Gigabit Ethernet and USB serial data lines. Up to 6 high-speed backplane connectors P1 - P6 are provided on a system slot controller such as the SC2-PRESTO, which can be considered as a root hub with respect to most signal lines. A passive backplane is used for distribution of a defined subset of I/O channels from the system slot to each of up to eight peripheral slots in a *CompactPCI® Serial* system.

The SC2-PRESTO is equipped with a set of local expansion interface connectors, which can be optionally used to attach a mezzanine side board. A variety of expansion cards is available, e.g. providing legacy I/O and additional PCI Express® based I/O controllers such as SATA, USB 3.0 and Gigabit Ethernet, or a third video output. Most mezzanine side cards can accommodate in addition a 2.5-inch drive.

The SC2-PRESTO is equipped with up to 16GB Low Power RAM with ECC support. 8GB memory-down are provided for rugged applications, and another 8GB are available via the DDR3L ECC SO-DIMM socket. The on-board SATA 6G RAID controller allows for powerful mass storage solutions via the CompactPCI® Serial backplane. Low profile SSD mezzanine modules are available as on-board storage solution, in addition.

Most *CompactPCI® Serial* peripheral slot cards require only the backplane connector P1, which comprises PCIe, SATA and USB signals, resulting in a concise and inexpensive peripheral board design. More powerful peripheral cards profit from so called Fat Pipe slots (PCIe x 8).

The SC2-PRESTO is a native *CompactPCI® Serial* CPU card, suitable for usage in a pure CPCI Serial environment. Due to its generous backplane capabilities (22 x PCI Express® lanes, 6 x USB2, 2 x USB3, 7 x SATA/RAID, 2 x GbE), very powerful industrial systems can be built.

Typically, the SC2-PRESTO and the related side card would come as a readily assembled 8HP unit. As an alternate, low profile Flash based mezzanine storage modules are available that fit on the SC2-PRESTO while maintaining the 4HP profile. The C47-MSATA module e.g. is equipped with two very fast MSATA Solid State Drives (SSD), which is suitable for installation of any popular operating system.



## Technical Features

### Feature Summary

#### Feature Summary

##### *General*

- ▶ PICMG® CompactPCI® Serial (CPCI-S.0) CPU card
- ▶ Form factor single size Eurocard (board dimensions 100x160mm<sup>2</sup>)
- ▶ Mounting height 3U
- ▶ Front panel width 4HP (8HP/12HP assembly with optional mezzanine side card)
- ▶ Front panel I/O connectors for typical system configuration (2 x USB3, 2 x DisplayPort, 2 x GbE)
- ▶ Backplane communication via PCI Express® Gen3, SATA 6G, USB 3.0, Gigabit Ethernet
- ▶ Local mezzanine expansion option (side card), COTS and custom specific boards

##### *Processor*

- ▶ 4<sup>th</sup> Generation Intel® Core™ CPU (Haswell)
- ▶ i7-4700EQ Processor 2.4/1.7GHz (TB 3.4GHz) • 47W/37W TDP • Quad-Core • GT2-4600 Graphics 1000MHz • vPRO™/AMT
- ▶ i5-4400E Processor 2.7GHz (TB 3.3GHz) • 37W TDP • Dual-Core • GT2-4600 Graphics 1000MHz • vPRO™/AMT
- ▶ i5-4410E Processor 2.9GHz • 37W TDP • Dual-Core • GT2-4600 Graphics 1000MHz • vPRO™/AMT
- ▶ i5-4422E Processor 1.8GHz (TB 2.9GHz) • 25W TDP • Dual-Core • GT2-4600 Graphics 900MHz • vPRO™/AMT
- ▶ i3-4110E Processor 2.6GHz • 37W TDP • Dual-Core • GT2-4600 Graphics 900MHz
- ▶ i3-4112E Processor 1.8GHz • 25W TDP • Dual-Core • GT2-4600 Graphics 900MHz
- ▶ Celeron 2000E Processor 2.2GHz • 37W TDP • Dual-Core • HD Graphics 900MHz
- ▶ Celeron 2002E Processor 1.5GHz • 25W TDP • Dual-Core • HD Graphics 900MHz

##### *Firmware*

- ▶ Phoenix® UEFI (Unified Extensible Firmware Interface) with CSM\*
- ▶ Fully customizable by EKF
- ▶ Secure Boot and Measured Boot supported - meeting all demands as specified by Microsoft®
- ▶ Windows®, Linux and other (RT)OS' supported
- ▶ Intel® AMT supported for i7 and i5 processors (disabled by default, must be enabled via BIOS setup)

\* CSM (Compatibility Support Module) emulates a legacy BIOS environment, which allows to boot a legacy operating system such as DOS, 32-bit Windows and some RTOS'

##### *Main Memory*

- ▶ Integrated memory controller up to 16GB DDR3L 1600 +ECC
- ▶ DDR3L +ECC soldered memory up to 8GB
- ▶ DDR3L +ECC SO-DIMM memory module socket up to 8GB

## Feature Summary

### *Performance Rating*

- ▶ Passmark 8.0 performance test (Windows 8.1/64, 16GB RAM, C47-MSATA mezzanine SSD storage module)
- ▶ SC2-680D (i7-4700EQ): Passmark rating 2686, CPU rating 7888

### *Graphics*

- ▶ Integrated HD Graphics Engine, 3 symmetric independent displays
- ▶ Enhanced Media Processing, DX11.1, OpenCL 1.2, OpenGL 4.3, JPEG, MJPEG, MVC, SVC, MPEG-2
- ▶ Front panel: Dual Mini-DisplayPort (mDP) or single VGA connector option
- ▶ 3<sup>rd</sup> DisplayPort connector via mezzanine side card
- ▶ DisplayPort™ 1.2 Multi-Stream Transport (MST) - display daisy chaining
- ▶ Max Resolution 3200 x 2000 @60Hz (any DisplayPort), 1920 x 1200 (VGA)
- ▶ 4k x 2k @24Hz supported for Blu-ray playback
- ▶ Integrated audio

### *Networking*

- ▶ Up to 4 networking interfaces in total - 2 x front RJ45 GbE, 2 x backplane GbE via P6
- ▶ 1000BASE-T, 100BASE-TX, 10BASE-T connections
- ▶ Front port 1 - I217LM with Intel® AMT support
- ▶ Front port 2 - Intel® I210-IT -40°C to +85°C operating temperature GbE NIC w. integrated PHY
- ▶ Front port option M12 X-coded connectors (replacement for RJ45, requires 8HP front panel width)
- ▶ IPv4/IPv6 checksum offload, 9.5KB Jumbo Frame support, EEE Energy Efficient Ethernet
- ▶ IEEE 802.1Qav Audio-Video-Bridging (AVB) enhancements for time-sensitive streams
- ▶ IEEE 1588 and 802.1AS packets hardware-based time stamping for high-precision time synchronization
- ▶ Backplane Gigabit Ethernet w. 2 x I210-IT NIC

### *Chipset*

- ▶ Intel® QM87 Lynx Point Platform Controller Hub (PCH)
- ▶ 8 x PCIe Gen2 5GT/s
- ▶ 6 x SATA 6G
- ▶ 10 x USB2, 4 x USB3
- ▶ LPC, Audio, Legacy

## Feature Summary

### *On-Board Building Blocks*

- ▶ Additional on-board controllers, PCIe® based
- ▶ 3 x Gigabit Ethernet controllers Intel® I210IT
  - ▶ one of them supporting IEEE 1588-2008 Precision Time Protocol including PPS and PPM signals
- ▶ 1 x Gigabit Ethernet PHY Intel® I217LM
- ▶ PCIe Gen2 packet switch 16-lane 16-port PLX 8618
- ▶ SATA 6G RAID controller Marvell® 88SE9230, ARM powered subsystem for host CPU offload

### *Security*

- ▶ Trusted Platform Module
- ▶ TPM 2.0 for highest level of certified platform protection
- ▶ Infineon Optiga™ SLB 9665 cryptographic processor
- ▶ Conforming to TCG 2.0 specification
- ▶ AES hardware acceleration support by 4<sup>th</sup> Gen processor 4xxx series (Intel® AES-NI)

### *Front Panel I/O (4HP)*

- ▶ 2 x Gigabit Ethernet RJ45 (1 = PCH & I217LM - iAMT, 2 = I210IT)
- ▶ 2 x DisplayPort (from processor integrated HD graphics engine, mDP style receptacles, optional cable connector retainer available)
- ▶ 2 x USB 3.0

### *CompactPCI® Serial Backplane Resources*

- ▶ PICMG® CPCI-S.0 CPU card & system slot controller
- ▶ 16 x PCIe Gen3 8GT/s (2 links x 8 for two fat pipe slots, derived directly from the Intel® Core™ CPU)
- ▶ 6 x PCIe Gen2 5GT/s (6 links x 1 for peripheral slots)
- ▶ 3 x SATA 6G (from PCH)
- ▶ 4 x SATA 6G (Marvell hardware RAID controller)
- ▶ 4 x USB2, 2 x USB3 (from PCH)
- ▶ 2 x Gigabit Ethernet (I210IT networking controllers)

## Feature Summary

### *Local Expansion and Mass Storage Solutions*

- ▶ Mezzanine side card connectors for optional local expansion
- ▶ P-EXP - 2 x USB 2.0 & Legacy (from PCH)
- ▶ P-DP3 - 3<sup>rd</sup> DisplayPort video (from Intel® Core™ CPU)
- ▶ P-HSE - 3 x SATA 6G & 4 x USB 2.0 (from PCH)
- ▶ P-PCIE - PCIe Gen2 5GT/s 1 link x 4 lanes (from on-board PCIe® switch)
  
- ▶ 4HP Low profile mezzanine module options
- ▶ CFast™ Card with C41-CFAST mezzanine module
- ▶ SATA 1.8-Inch Solid State Drive with C42-SATA mezzanine module
- ▶ Dual mSATA SSD with C47-MSATA mezzanine module
- ▶ Triple M.2/NGFF SATA SSD 2230 - 2280 size with C48-M2 mezzanine module
- ▶ Custom specific module design
  
- ▶ 8HP/12HP Mezzanine side card options
- ▶ SCS-TRUMPET - 3<sup>rd</sup> DisplayPort F/P connector, RS-232, 2 x USB3, on-board 2.5-Inch SATA SSD or 2 x M.2/NGFF SATA SSD module sockets 2230 - 2280
- ▶ Variety of other side cards available
- ▶ Custom specific side card design

### *Environmental & Regulatory*

- ▶ Suitable e.g. for industrial, transportation & instrumentation applications
- ▶ Designed & manufactured in Germany - ISO 9000 quality management certified
- ▶ Long term availability
- ▶ Rugged solution
- ▶ Coating, sealing, underfilling on request
- ▶ Lifetime application support
- ▶ RoHS compliant
- ▶ Operating temperature 0°C to +70°C
- ▶ Operating temperature -40°C to +85°C (industrial temperature range) on request
- ▶ Storage temperature -40°C to +85°C, max. gradient 5°C/min
- ▶ Humidity 5% ... 95% RH non condensing
- ▶ Altitude -300m ... +3000m
- ▶ Shock 15g 0.33ms, 6g 6ms
- ▶ Vibration 1g 5-2000Hz
- ▶ MTBF 11.7 years (SC2-680D)
- ▶ EC Regulatory EN55022, EN55024, EN60950-1 (UL60950-1/IEC60950-1)

## Feature Summary

### *RT OS Board Support Packages & Driver*

- ▶ LynxOS - on request
- ▶ On Time RTOS-32 - on request
- ▶ OS-9 - on request
- ▶ QNX 4.x, 6.x - on request
- ▶ Real-Time Linux (RT Patch) - on request
- ▶ RTX - on request
- ▶ VxWorks 5.5 & 6.9 - on request
- ▶ VxWorks 7.0 - under development
- ▶ Others - on request

all items are subject to change w/o further notice

## Power Requirements

Power Requirements		
Board	Load Current [A] at +12V (±5%)	
	Maximum Performance LFM / HFM / Turbo <sup>1)</sup>	Windows 8 Idle LFM / HFM / Turbo <sup>1)</sup>
SC2-68XX	2.2 / 4.0 / 4.2 <sup>2)</sup>	1.2 / 1.2 / 1.2 <sup>2)</sup>
SC2-48XX	1.8 / 3.0 / 3.1 <sup>2)</sup>	1.1 / 1.1 / 1.1 <sup>2)</sup>
SC2-28XX	tbd / tbd / tbd <sup>2)</sup>	tbd / tbd / tbd <sup>2)</sup>
	Load Current [A] at +5V[STDBY] (±5%) <sup>3)</sup>	
	Full On / Sleep / Hibernate / Soft Off (S0 / S3 / S4 / S5)	0 / 0 / 0 / 0.1

<sup>1)</sup> Intel SpeedStep Frequency Modes LFM: Low Frequency Mode, HFM: High Frequency Mode.

<sup>2)</sup> Add 10/100mA (link only/active) @1Gbps per Ethernet Port.

<sup>3)</sup> This power supply is optional. It can be left open if not available.



Block Diagram

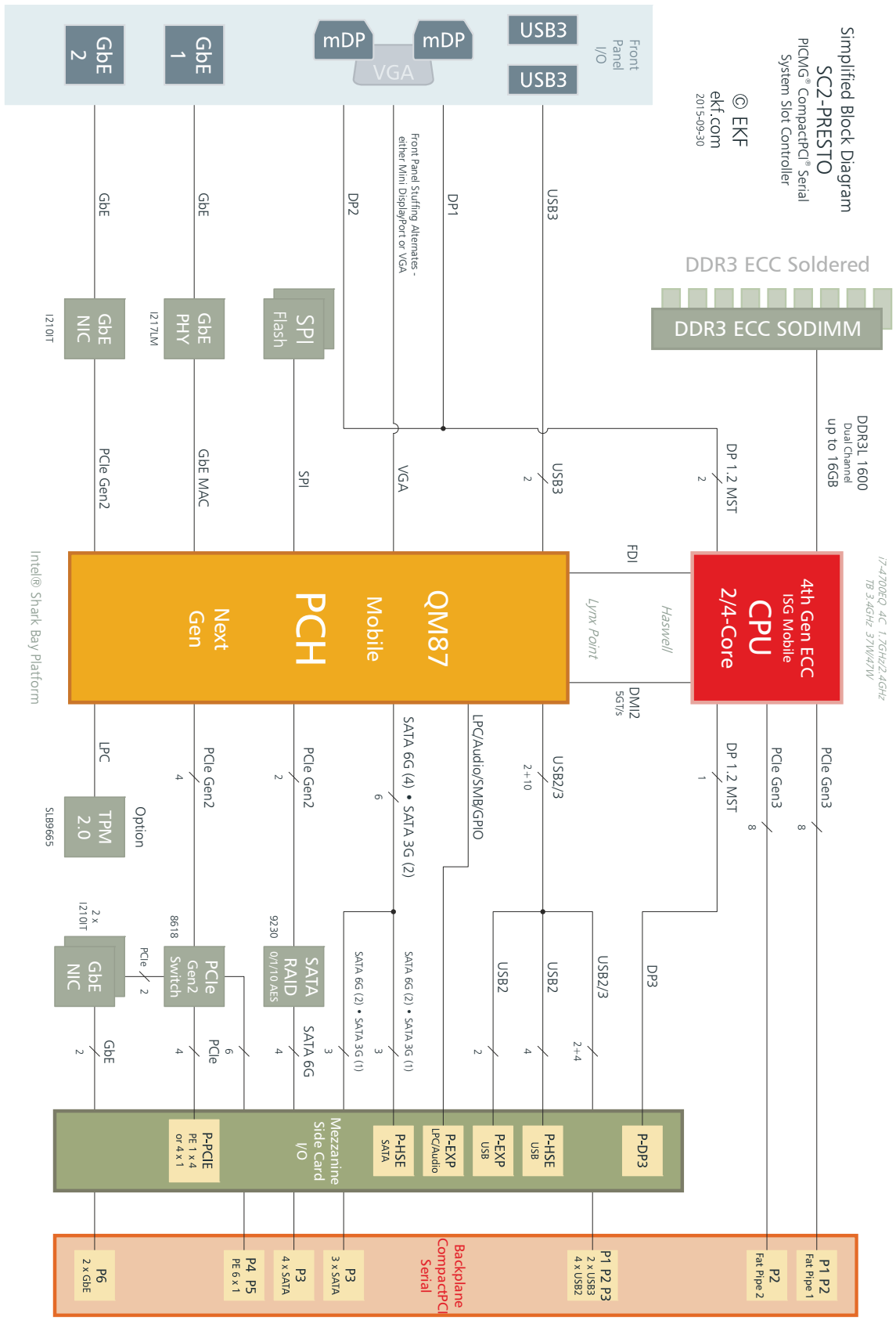

[www.ekf.com/s/sc2/img/sc2\\_blk.pdf](http://www.ekf.com/s/sc2/img/sc2_blk.pdf)

Top View Component Assembly

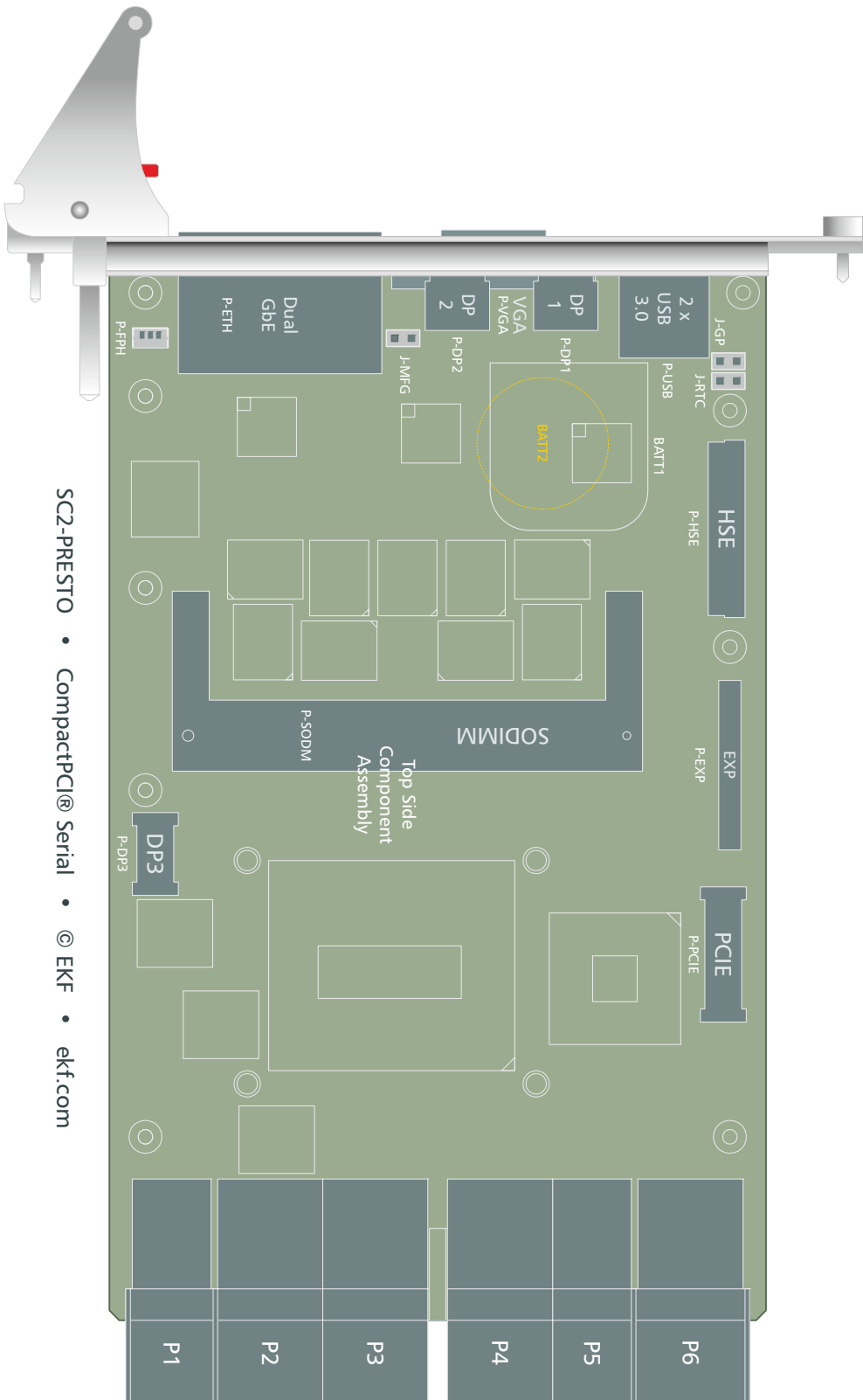

## Bottom View Component Assembly

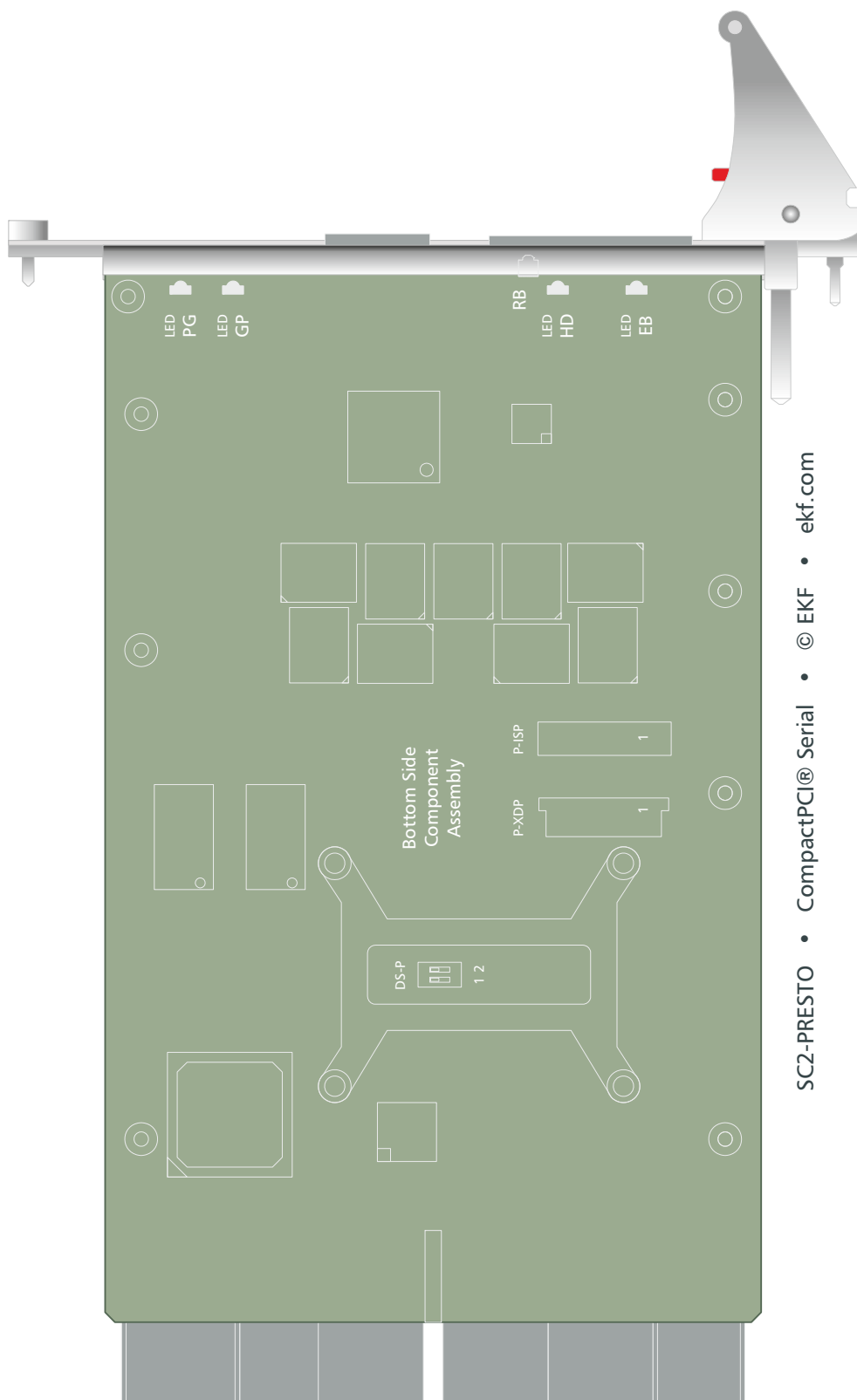

SC2-PRESTO • CompactPCI® Serial • © EKF • ekf.com

## Front Panel Connectors

ETH1/2	Dual Gigabit Ethernet RJ-45 receptacles with integrated indicator LEDs
DP1/2	Mini DisplayPort digital video output receptacle (VGA connector available as alternate)
USB1/2	Universal Serial Bus 3.0 type A receptacles
VGA	VGA analog video output connector (Mini DisplayPort connectors available as alternate)

## Front Panel Switches & Indicators

EB	LED indicating Backplane Ethernet activity
FPH	Front Panel Handle with integrated switch (programmable function, power event button by default)
GP	General Purpose bicolour LED
HD	Bicoloured LED indicating any activity on SATA ports
PG	Power Good/Board Healthy bicolour LED
RB	System Reset Button (Option)

## On-Board Connectors & Sockets

P-EXP	Utility EXPansion Interface Connector (LPC, USB, HD Audio, SMBus), interface to optional side board
P-HSE	High Speed Expansion Connector (3 x SATA, 4 x USB), interface to optional low profile mezzanine module or side board
P-PCIE	PCI Express® Expansion Interface Connector, interface to optional side board
P-DP3	Digital Display Interface Connector, interface to optional 3 <sup>rd</sup> DisplayPort on side board
P1	<i>CompactPC</i> ® Serial Type A Connector
P2-P4	<i>CompactPC</i> ® Serial Type B Connectors
P5	<i>CompactPC</i> ® Serial Type C Connector
P6	<i>CompactPC</i> ® Serial Type D Connector
P-SODM	204-pin DDR3L ECC Memory Module SDRAM PC3L-12800 Socket (ECC SODIMM)
P-XDP	CPU Debug Port <sup>1)</sup>

<sup>1)</sup> Connector populated on customers request only

## Pin Headers

P-FPH	Pin header suitable for Front Panel Handle switch cable harness
P-ISP	PLD glue logic device programming connector, not populated

## Jumpers

DS-P	Switches to configure link width and speed on P-PCIE
J-GP	Jumper to reset UEFI BIOS Setup to EKF Factory Defaults, IEEE 1588 Pulse per Second Output
J-MFG	Jumper to enter Manufacturing Mode, not populated
J-RTC	Jumper to reset RTC circuitry (part of PCH), not populated

## Microprocessor

The SC2-PRESTO is equipped with an Intel® Core™ i7, i5 or i3 4<sup>th</sup> generation mobile ECC processor (code name "Haswell"). These low power processors provide integrated graphics, memory controller and voltage regulators, which results in a very efficient platform design.

The Core™ i7/i5/i3 processor family includes units with several thermal design power (TDP) classes to fit the customers requirements: 47W, 37W and 25W. The processors are housed in a Micro FC-BGA package for direct soldering to the PCB, i.e. the chip cannot be removed or changed by the user.

The processors supported by the SC2-PRESTO are running at core clock speeds up to 2.4GHz for quad core and up to 2.7GHz on dual core devices. Due to Enhanced Intel® SpeedStep® and Intel® Turbo Boost Technology each core can decrease or increase its nominal operating frequency. The clock speed is chosen depending on the power states of the processor cores/graphics engine, the currently required performance, and the actual core temperature.

Power is applied across the *CompactPCI*® connector P1 (12V). The processors core voltage are generated by a switched voltage regulator according to Intel's VR12.5 voltage regulator specification.

Intel® Core™ Processors Supported <sup>1)</sup>									
Processor Number	Physical Cores	Core Clock nom./max. [GHz]	Cache [MB]	Gfx Clock [MHz]	Junction Temp. [°C]	TDP [W]	CPU ID	Stepping	SPEC Code
i7-4700EQ <sub>2)</sub>	4	2.4/3.4 2.2/3.2	6	400-1200 400-1150	100	47 37	40661h	C-0	SR17L
i5-4400E	2	2.7/3.3	3	400-1000	100	37	40661h	C-0	SR17M
i5-4422E	2	1.8/2.9	3	400-900	100	25	40661h	C-0	SR1T1
2002E	2	1.5/1.5	2	400-900	100	25	40661h	C-0	SR17P

<sup>1)</sup> The processors listed are units with long life support.

<sup>2)</sup> This processor may run with different TDPs configurable by BIOS settings.

## Thermal Considerations

In order to avoid malfunctioning of the SC2-PRESTO, take care of appropriate cooling of the processor and system, e.g. by a cooling fan suitable to the maximum power consumption of the CPU chip actually in use. The processor contains digital thermal sensors (DTS) that are readable via special CPU registers. DTS allows to get the temperatures of each CPU core separately.

Two further temperature sensors, located in the system hardware monitor LM87, allows for acquisition of the boards surface temperature and the thermal state of the onboard system memory channel. Beside this the LM87 also monitors most of the supply voltages. A suitable software on Microsoft Windows® systems to display both, the temperatures as well as the supply voltages, is Speedfan, which can be downloaded from the web. After installation, both temperatures and voltages can be observed permanently from the Windows® taskbar.

The SC2-PRESTO is equipped with a passive heatsink. Its height takes into account the 4HP limitation in mounting space of a CompactPCI® board. In addition, a forced vertical airflow through the system enclosure (e.g. bottom mount fan unit) is strongly recommended ( $>20\text{m}^3/\text{h}$  or  $2\text{m/s}$  (400LFM) around the CPU slot). Be sure to thoroughly discuss your actual cooling needs with EKF. Generally, the faster the CPU speed the higher its power consumption. For higher ambient temperatures, consider increasing the forced airflow to  $3\text{m/s}$  (600LFM) or more.

The table showing the supported processors above give also the maximum power consumption (TDP) of a particular processor. Fortunately, the power consumption is by far lower when executing typical Windows® or Linux tasks. The heat dissipation increases when e.g. rendering software like the Acrobat Distiller is executed.

The Core™ processors support Intel's Enhanced SpeedStep® technology. This enables dynamic switching between multiple core voltages and frequencies depending on core temperature and currently required performance. The processors are able to reduce their core speed and core voltage in multiple steps down to 800MHz. Additionally a reduction of the graphics core clock (down to 200MHz) and voltage is possible. This leads to an obvious reduction of power consumption resulting in less heating.

A further way to reduce power consumption is achieved by integrating the voltage regulators on the die of the 4<sup>th</sup> generation Core™ processors. This embedding allows the processor to regulate the voltages to each core, graphics, cache and other units separately depending on their performance needs. Parts that are currently idle may be switched off to save power.

## Main Memory

The SC2-PRESTO features two channels of DDR3L SDRAMs with support of ECC (Error Correction Code). One channel is realized with 18 memory devices soldered to the board (Memory Down) and delivers a capacity of up to 8GB with a clock frequency of 1600MHz (PC3L-12800).

The 2nd channel provides a socket for installing a 204-pin ECC SODIMM module thus allowing a simple expansion of system memory (max. module height = 1.25 inch). Supported are unbuffered DDR3L ECC SODIMMs (72-bit) with  $V_{DD}=1.35V$  featuring on-die termination (ODT), according the PC3L-12800 specification. Minimum module size is 512MB; maximum module size is 8GB. Please note that neither standard DDR3 SODIMMs nor DDR3L without ECC feature do not work on SC2-PRESTO.

It is recommended to add a SODIMM module with same size as the Memory Down to get best performance. Since some of the system memory is dedicated to the graphics controller a typically development of 2x4GB of memory is recommended to run operating systems like Windows® 7 or Windows® 8.

The memory controller supports symmetric and asymmetric memory organization. The maximum memory performance can be obtained by using the symmetric mode. When in this mode, the memory controller accesses the memory channels in an interleaved way. Since Core™ processors support Intel's Flex Memory Technology, interleaved operation isn't limited to systems using memory channels of equal capacity. In the case of unequal memory population the smaller memory channel dictates the address space of the interleaved accessible memory region. The remainder of the memory is then accessed in non-interleaved mode.

In asymmetric mode the memory always will be accessed in a non-interleaved manner with the drawback of less bandwidth. The only meaningful application of asymmetric mode is the special case when only one memory channel is populated (i.e. the SODIMM socket may be left empty).

The contents of the SPD EEPROM on the SODIMM is used by the BIOS at POST (Power-on Self Test) to get any necessary timing parameters to program the memory controller within the chipset.



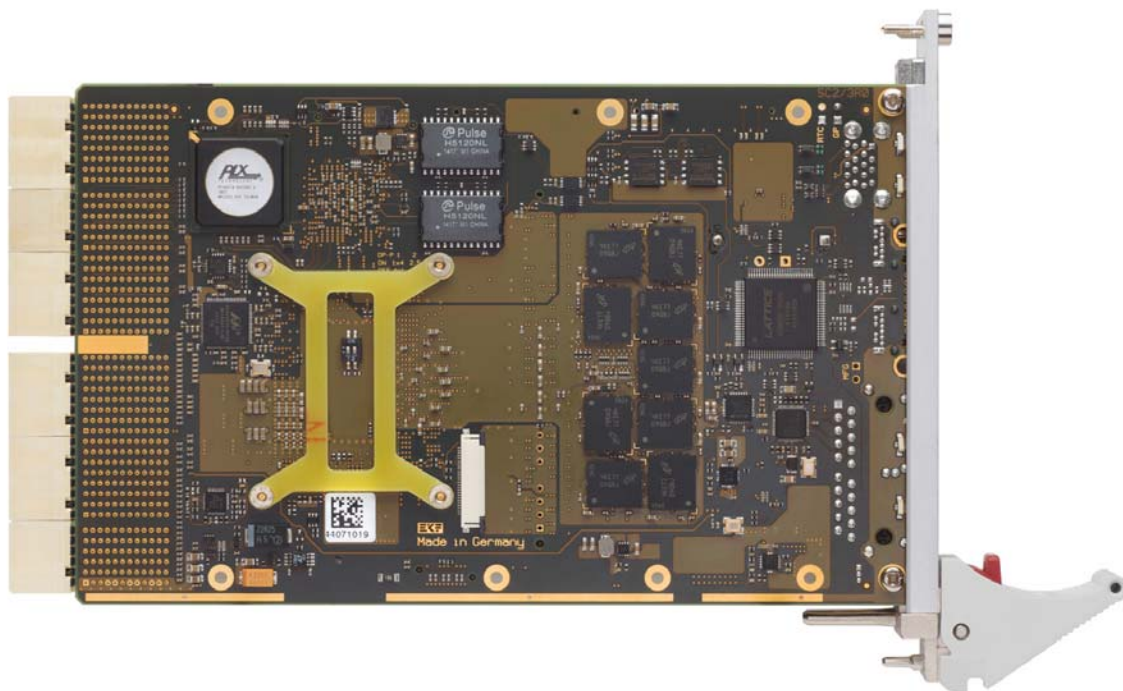

Soldered Memory

## Graphics Subsystem

The structure of the graphics subsystem has changed compared to the predecessor of the Intel 4<sup>th</sup> generation Core™ processor. The main graphics interfaces like DisplayPort and DVI are part of the processor. Only a few sideband signals (DDC/Auxiliary channel, hot plug detection) as well as the VGA interface is remained at the PCH QM87.

The SC2-PRESTO offers two Mini DisplayPort (mDP) interfaces in the front panel. Adapters to convert Mini DisplayPort to any other popular interface standard are available.

A 3<sup>rd</sup> DisplayPort is fed to the on-board connector P-DP3. EKf expansion boards like PCS-BALLET feature the possibility to gain access to the 3<sup>rd</sup> DisplayPort interface.

As an alternate, the SC2-PRESTO can be equipped with an ordinary HD D-Sub 15-lead connector (VGA style). This connector is suitable for analog signals only. Nevertheless also flat-panel displays can be attached to the D-Sub connector but with minor reduced image quality.

Independent from the video connector actually in use, Mini DisplayPort, DVI or VGA, the VESA DDC standard is supported. This allows to read out important parameters, e.g. the maximum allowable resolution, from the attached monitor. DDC power, +3.3V on DisplayPort connectors, is delivered via electronic switches to protect the board from an external short-circuit condition (1.5A) and to prevent back current flows. On the VGA interface a resettable fuse (0.5A) is used supply the +5V DDC power.

Graphics drivers can be downloaded from the Intel web site.

## LAN Subsystem

The Ethernet LAN subsystem is composed of four Gigabit Ethernet ports: One Intel i217LM Physical Layer Transceiver (PHY) using the PCH QM87 internal MAC and three Intel i210IT Gigabit Ethernet Controllers. These devices provide also legacy 10Base-T and 100Base-TX connectivity. Two of the Ethernet ports are fed to two RJ45 jacks located in the front panel, the others are attached to the CompactPCI® Serial interface on P6. Each port includes the following features:

- ▶ One PCI Express lane per Ethernet port (250MB/s)
- ▶ 1000Base-Tx (Gigabit Ethernet), 100Base-TX (Fast Ethernet) and 10Base-T (Classic Ethernet) capability.
- ▶ Half- or full-duplex operation.
- ▶ IEEE 802.3u, 802.3ab Auto-Negotiation for the fastest available connection.
- ▶ Jumperless configuration (complete software-configurable).

Two bicoloured LEDs integrated into the dedicated RJ-45 connector in the front panel are used to signal the LAN link, the LAN connection speed and activity status. A further bicoloured LED in front panel labelled EB displays the state of the backplane network ports.

Each device is connected by a single PCI Express lane to the PCH. Their MAC addresses (unique hardware number) are stored in dedicated FLASH/EEPROM components. The Intel Ethernet software and drivers for the i217LM and i210IT are available from Intel's World Wide Web site for download.

When managing the board by Intel Active Management Technology (iAMT), the dedicated network port to do so is accessible by the RJ45 connector GbE1 (the upper port within the front panel).

Although any of the i210 controllers support the IEEE 1588 Precision Time Protocol, the one connected to GbE2 (the lower port within the front panel) is capable to generate Pulse per Second (PPS) and Pulse per Minute (PPM) signals that may be routed to the jumper J-GP and the *CompactPCI*® Serial connector P1. These signals can be used to trigger events on Mezzanine Side Boards or Peripheral Boards. The following routing is possible by UEFI BIOS settings:

- ▶ Pulse per Second (PPS): J-GP Pin 1 and *CompactPCI*® Pin J3 (signal SATA-SCL)
- ▶ Pulse per Minute (PPM): *CompactPCI*® Pin H3 (signal SATA-SDO)

## Serial ATA Interface (SATA)

The SC2-PRESTO provides a total of ten serial ATA (SATA) ports, derived from up to three independent SATA controllers. Eight of these ports support data transfer rates of 6Gbps (600MB/s), 3Gbps (300MB/s) or 1.5Gbps (150MB/s), the remaining two ports up to 3Gbps. SATA controllers are located within the QM87 Platform Controller Hub that holds 6 SATA interfaces and in a separate SATA host controller Marvell 88SE9230, providing four SATA ports, all 6Gbps capable.

Three of the QM87 ports are fed to the high speed expansion connector P-HSE. This connector allows the installation of low profile expansion boards like C41-CFAST or C42-SATA to attach the popular CFAST cards or Micro SATA SSDs (1.8-inch) respectively. Another mezzanine is the C47-MSATA, a carrier for two MSATA SSD modules.

The Marvell 88SE9230 is a SATA 6Gbps AHCI/RAID I/O controller connected via two PCI Express lanes (1GB/s) to the QM87. It supports hardware RAID levels 0, 1 and 10. All of its SATA ports as well as the three remaining QM87 ports are used to supply the *CompactPCI*® Serial SATA interfaces on the backplane.

A LED named HD located in the front panel, signals disk activity status of any QM87 SATA devices (green) or 88SE9230 devices (yellow).

Additionally a variety of side cards is available, suitable for mounting on the SC2-PRESTO in a 4HP (20.32mm) distance (resulting in 8HP front panel width for the assembly). Some of these side boards can accommodate a SATA drive, e.g. a 2.5-inch SSD.

Available for download from Intel's web site are drivers for popular operating systems, e.g. Windows® 7, Windows® 8 and Linux.

Drivers and software to manage the RAID configuration of the 88SE9230 (Windows® application) is provided by Marvell and can be downloaded from EKF's website.

## PCI Express® Interface

The SC2-PRESTO is provided with several PCI Express (PCIe) lanes for I/O expansion. Sixteen PCI Express lanes, originating from the Core™ processor, are building the two fat pipes defined by *CompactPCI*® Serial. These two links consists of eight lanes with transfer rates of up to 8Gbps (PCI Express Gen 3).

The QM87 offers a total of eight PCI Express ports supporting PCIe Gen 2 speed (5GT/s). Four of them form the upstream link to a PCI Express switch. The output ports (downstream ports) of the PCIe switch are connected to the *CompactPCI*® Serial connectors P4/P5 (six lanes), to the local PCIe expansion interface connector P-PCIE (four lanes) and to two of the Ethernet controllers (i210IT).

Two small DIP switches (DS-P) located on the backside of the board are used to configure different lane widths to each of both downstream interfaces and to choose the interface transfer rate. Possible settings are

- ▶ Six links x 1 to *CompactPCI*® Serial P4/P5, two links x 1 to i217IT and a single link x 4 to P-PCIE
- ▶ Six links x 1 to *CompactPCI*® Serial P4/P5, two links x 1 to i217IT and four links x 1 to P-PCIE
- ▶ 2.5GT/s or 5GT/s transfer speed

See section “Configuration PCI Express Switch (DS-P)” for details.

## Universal Serial Bus (USB)

The SC2-PRESTO is provided with fourteen USB ports. All of them are USB 2.0 capable, but four ports are also supporting the USB 3.0 SuperSpeed standard. Two USB 3.0 interfaces are routed to front panel connectors, the other two SuperSpeed ports are feed to the *CompactPCI*® Serial connectors P1 and P3.

The USB 2.0 interfaces are distributed to the front panel (two ports), two to the expansion board interface connectors P-EXP, four to the high speed expansion connector P-HSE, and six ports are available across the backplane connectors for *CompactPCI*® Serial.

The front panel USB connectors can source a minimum of 1.5A/5V each, over-current protected by two electronic switches. Protection for the USB ports on the expansion interfaces and on the *CompactPCI*® Serial connectors is located on expansion boards and the boards on the *CompactPCI*® Serial backplane respective. The USB xHCI and two EHCI controllers handling the USB port operation at SuperSpeed, high-speed, full-speed and low-speed are integrated into the QM87 PCH.

An xHCI driver (USB 3.0) for Windows® 7 is provided by Intel and can be downloaded from EKF's website.

## Utility Interfaces

Besides the high speed mezzanine interface connectors P-HSE and P-PCIE, the SC2-PRESTO is provided with the utility interface expansion connector socket P-EXP. This connector comprises several interfaces, which may be useful for system expansion on mezzanine cards, as an option:

- ▶ HD Audio
- ▶ LPC (Low Pin Count)
- ▶ SMBus
- ▶ 2 x USB

The SMBus is controlled by the QM87 platform controller hub. The SMBus signal lines on the P-EXP utility expansion connector can be switched on/off under software control (PCH GPIO) in order to isolate external components in case of an I<sup>2</sup>C address conflict.

The HD Audio port requires an additional audio codec, as provided e.g. on the PCS-BALLET side card.

The LPC bus presents an easy way to add legacy interfaces to the system. EKF offers a variety of mezzanine expansion boards (side cards), to be attached on top of the SC2-PRESTO, featuring all classic Super-I/O functionality, for example the PCS-BALLET. Access to the connectors PS/2 (mouse, keyboard), COM, USB and audio in/out is given directly from the front panel.

## Real-Time Clock

The SC2-PRESTO has a time-of-day clock and 100-year calendar, integrated into the QM87 PCH. A battery on the board supplies the clock circuitry whenever the computer main power is turned off. The SC2-PRESTO uses a holder to retain a BR2032 lithium coin cell, giving an autonomy of more than 5 years. Under normal conditions, replacement should be superfluous during lifetime of the board.

Alternately a leaded BR2032 battery can be soldered directly to the board for increased ruggedness, or if the SC2-PRESTO PCB shall be coated.

In applications where the use of a battery is not permitted, a SuperCap can be soldered instead of the battery.



SC2-PRESTO w. Coin Cell Holder



## SPI Flash

The BIOS and iAMT firmware is stored in flash devices with Serial Peripheral Interface (SPI). Up to 16MByte of BIOS code, firmware and user data may be stored nonvolatile in these SPI Flashes.

The SPI Flash contents can be updated by a DOS or Linux based tool. This program and the latest SC2-PRESTO BIOS binary are available from the EKF website. Read carefully the enclosed instructions. If the programming procedure fails e.g. caused by a power interruption, the SC2-PRESTO may no more be operable. In this case you would possibly have to send in the board, because the Flash device is directly soldered to the PCB and cannot be changed by the user.

## Reset

The SC2-PRESTO is provided with several supervisor circuits to monitor supply rails like the CPU core voltage, 1.5V, 3.3V or 5V.

To force a manual board reset, the SC2-PRESTO offers a small tactile switch within the front panel. This push-button is indent mounted and requires a tool, e.g. a pen to be pressed, preventing from being inadvertently activated.

The handle within the front panel contains a micro switch that is used to generate a power button event. By pressing the handle's red push button a pulse is triggered.

Animated GIF: [www.ekf.com/c/ccpu/img/reset\\_400.gif](http://www.ekf.com/c/ccpu/img/reset_400.gif)

NOTE: To prevent the board to cause a power button override, the handle should be closed immediately after unlocking the front panel handle. A power button override is triggered by opening the front panel handle for at least 4 seconds, which results in bringing the board to power state S5. In case of entering this state, unlock and lock the front panel handle a 2<sup>nd</sup> time to reenter normal power state S0 again. See also section 'PG (Power Good) LED' to see how the SC2-PRESTO indicates the different power states.

WARNING: The SC2-PRESTO will enter the power state S5 if the front panel handle is not closed properly when the system powers up. An open handle is signalled by a yellow blinking 'PG LED'.

The manual reset push-button and the power button functionality of the front panel handle could be passivated by BIOS settings.

An alternative (and recommended) way to generate a system reset is to activate the signal PRST# located on *CompactPCI*® Serial connector P1 pin H2. Pulling this signal to GND will have the same effect as to push the tactile reset switch.

The healthy state of the SC2-PRESTO is indicated by the LED PG (Power Good) located in the front panel. This bicoloured LED signals different states of the board (see section below). As soon as this LED begins to lite green, all power voltages are within their specifications and the reset signal has been deasserted.

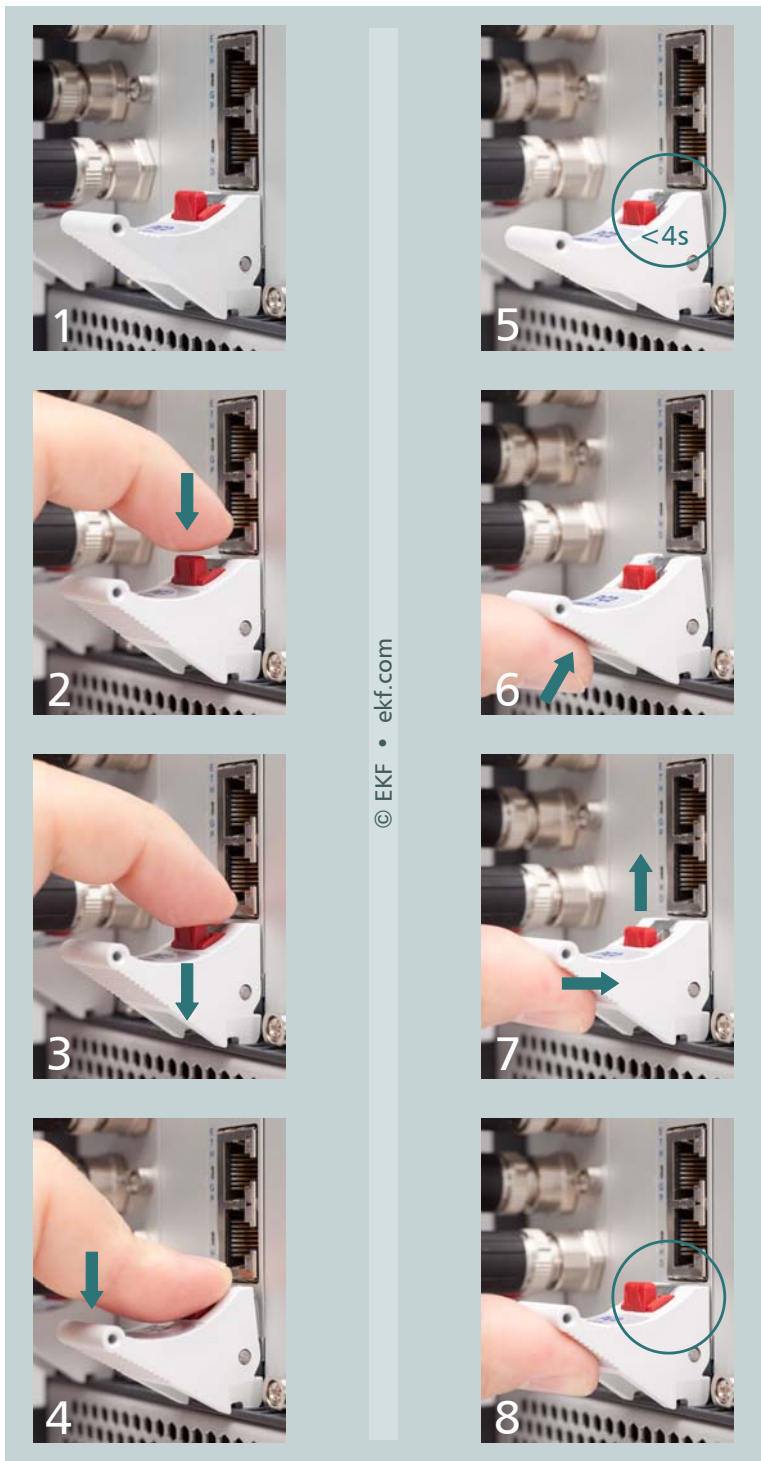

## Watchdog

An important reliability feature is a software programmable watchdog function. The SC2-PRESTO contains two of these watchdogs. One is part of the QM87 PCH and also known as TCO Watchdog. A detailed description is given in the QM87 data sheet. Operating systems like Linux offer a driver interface to the TCO watchdog.

The behaviour of the 2<sup>nd</sup> watchdog is defined within a PLD of the SC2-PRESTO, which activates/deactivates the watchdog and controls its time-out period. The time-out delay is adjustable in the steps 2, 10, 50 and 255 seconds. After alerting the WD and programming the time-out value, the related software (e.g. application program) must trigger the watchdog periodically. For details on programming the watchdog see section "Board Control and Status Register (BCSR)".

This watchdog is in a passive state after a system reset. There is no need to trigger it at boot time. The watchdog is activated on the first trigger request. If the duration between two trigger requests exceeds the programmed period, the watchdog times out and a full system reset will be generated. The watchdog remains in the active state until the next system reset. There is no way to disable it once it has been put on alert, whereas it is possible to reprogram its time-out value at any time.

## Front Panel LEDs

The SC2-PRESTO is equipped with four LEDs which can be observed from the front panel. Three of these LEDs are labelled according to their primary meaning, but should be interpreted altogether for system diagnosis:

LED			Status
PG Green/Red	GP Green/Red	HD Green/Yellow	
OFF	GREEN	GREEN	Sleep State S5 (Soft Off)
OFF	GREEN	OFF	Sleep State S4 (Suspend to Disk/Hibernate)
OFF	OFF	GREEN	Sleep State S3 (Suspend to RAM/Standby)
GREEN	RED BLINK	X	After Reset
GREEN	X	X	Board Healthy and in S0 State
YELLOW BLINK	X	X	Front panel handle is unlocked
RED	X	X	Hardware Failure - Power Fault
RED BLINK	X	X	Software Failure

## PG (Power Good) LED

The SC2-PRESTO offers a bicolour LED labelled PG located within the front panel. After system reset, this LED defaults to signal different power states:

- ▶ Off                Sleep state S3, S4 or S5
- ▶ Green            Healthy
- ▶ Yellow blink    Front panel handle open
- ▶ Red steady     Hardware failure
- ▶ Red blink      Software failure

To enter the PG LED state *Software Failure*, the bit PGLED in the board control register CTRLH\_REG must be set. The PG LED remains in this red blinking state until this bit is cleared. After that it falls back to its default function.

## GP (General Purpose) LED

This programmable bicolour LED can be observed from the SC2-PRESTO front panel. The status of the red part within the LED is controlled by the GPIO18 of the PCH QM87. Setting GPIO18 to "1" will switch on the red LED. Turning on or off the green LED is done by setting the bit GPLED in the board control register CTRLH\_REG.

The GP LED is not dedicated to any particular hardware or firmware function with exception of special power states of the LED PG as described above. Nevertheless, a red blinking GP LED is an indication that the BIOS code couldn't start.

While the CPU card is controlled by the BIOS firmware, the GP LED is used to signal board status information during POST (Power On Self Test). After successful operating system boot, the GP LED may be freely used by customer software. For details please refer to [www.ekf.com/s/sc2/firmware/biosinfo.txt](http://www.ekf.com/s/sc2/firmware/biosinfo.txt).

## HD (Hard Disk Activity) LED

The SC2-PRESTO offers a bicoloured LED marked as HD placed within the front panel. This LED, when blinking green, signals activity on any device attached to the SATA ports of the QM87.

The yellow part of the HD LED shows activity on any of the 88SE9230 SATA ports.

As previously described, the green part of this LED may change its function dependent on the state of the LED PG.

## EB (Ethernet Backplane) LED

To monitor the link status and activity on both Ethernet ports attached to the backplane via the *CompactPCI*® Serial connector P6 a single bicoloured LED is provided in the front panel. The states are decoded as follows:

1_ETH	2_ETH	LED EB
no link	no link	OFF
link	no link	GREEN
no link	link	YELLOW
link	link	GREEN/YELLOW

Blinking of the LED EB in the appropriate colour means that there is activity on the port.

## Main Power Supply Control (PS\_ON#)

The SC2-PRESTO draws its power from the +12V main supply rail defined by the *CompactPCI*® Serial specification. The board has been designed to control this main power supply by use of the signal PS\_ON# (connector P1 pin E2). If the system enters the sleep state S5 (soft off), the signal PS\_ON# is pulled high, hence the main power supply is switched-off. The SC2-PRESTO is held in soft off state until a power management event (e.g. power button event triggered by the front panel handle) brings back the system to the S0 state.

In order to work as described above and to generate clean signals on PS\_ON#, the stand-by voltage +5VSTB is necessary. This optional power rail, tied to connector P1 pin B1, is also part of the *CompactPCI*® Serial specification. The stand-by power rail must be switched-on "always", independent of the state of PS\_ON#.

Nevertheless, +5VSTB is not mandatory to operate the SC2-PRESTO. If no stand-by power is available, the board creates this voltage from the main power rail. In this case it is important that the PS\_ON# signal is pulled down somewhere in the system.

## Power Supply Status (PWR\_FAIL#)

Power supply failures may be detected before the system crashes down by monitoring the signal PWR\_FAIL#. This active low line (connector P1 pin F3) is an addition to the *CompactPCI*® Serial specification and may be driven by the power supply. PWR\_FAIL# signals the possible failure of the main supply voltage +12V. On the SC2-PRESTO the signal PWR\_FAIL# is routed to GPIO4 of the QM87 PCH to analyse the state of the power supply unit.

## Mezzanine Side Board Options

The SC2-PRESTO is provided with several stacking connectors for attachment of a mezzanine expansion module (aka side board), suitable for a variety of readily available mezzanine cards (please refer to [www.ekf.com/c/ccpu/mezz\\_ovw.pdf](http://www.ekf.com/c/ccpu/mezz_ovw.pdf) for a more comprehensive overview). EKF furthermore offers custom specific development of side boards (please contact [sales@ekf.de](mailto:sales@ekf.de)).

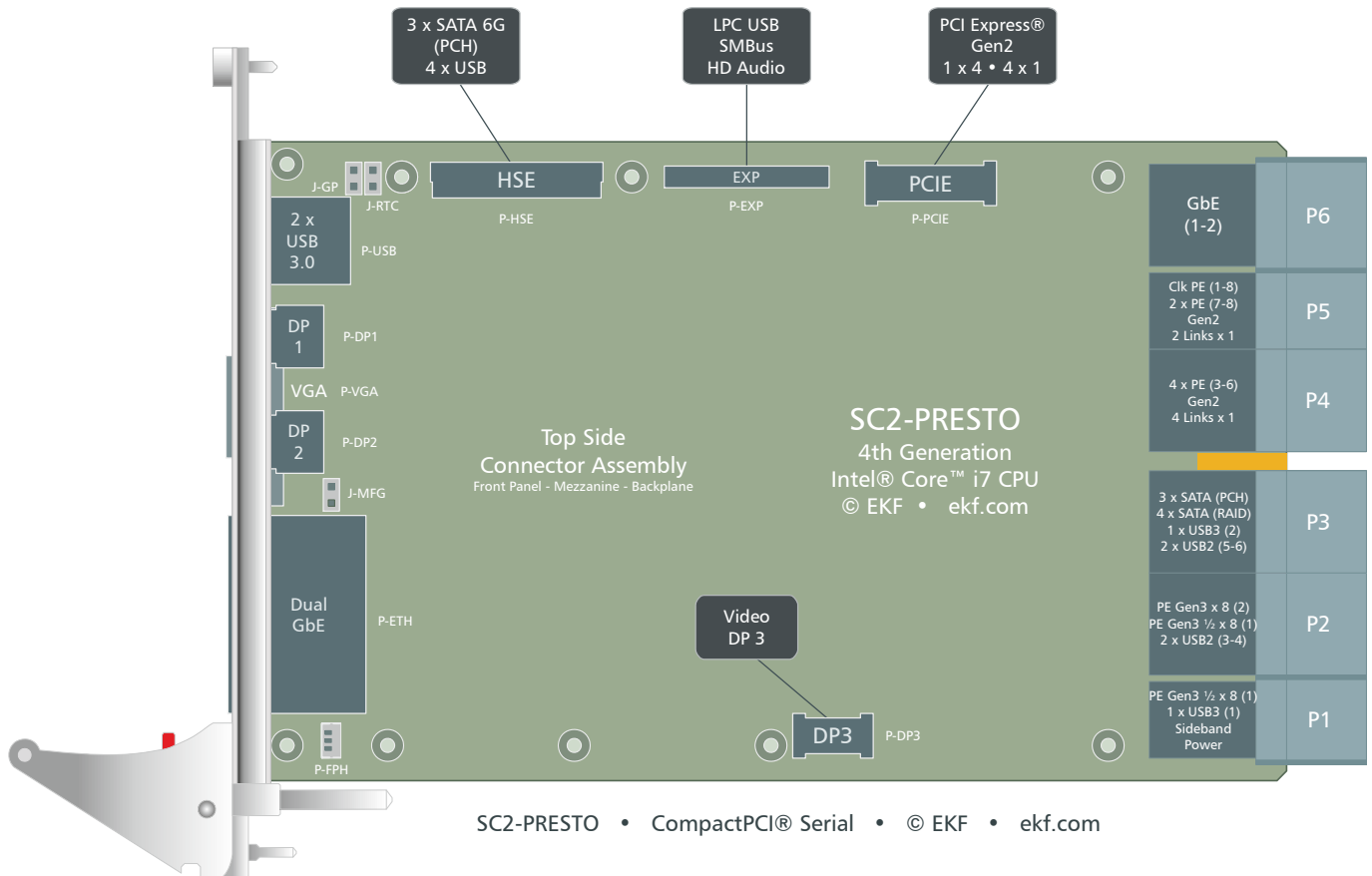

Most mezzanine expansion modules require an assembly height of 8HP in total, together with the CPU carrier board (resulting from two cards at 4HP pitch each).

In addition, cropped low profile mass storage mezzanine modules can be attached to P-HSE, which maintain the 4HP envelope, for extremely compact systems. Furthermore these small size modules may be combined with the full-size expansion boards (that means an assembly comprised of 3 PCBs).

### Related Documents Mezzanine Modules and Side Cards

C4* Series Mezzanine Storage Modules	<a href="http://www.ekf.com/c/ccpu/c4x_mezz_ovw.pdf">www.ekf.com/c/ccpu/c4x_mezz_ovw.pdf</a>
SCS-TRUMPET Mezzanine Side Card	<a href="http://www.ekf.com/s/csc/scs.html">www.ekf.com/s/csc/scs.html</a>



P-EXP	
I/F Type	Controller
LPC (Low Pin Count)	PCH
HD Audio	PCH
SMBus	PCH (buffered)
2 x USB 2.0	PCH

P-HSE	
I/F Type	Controller
SATA1, SATA2, SATA3	PCH
4 x USB 2.0	PCH

P-PCIE	
I/F Type	Controller
PCI Express® Gen2 1x4 or 4x1	PE Switch

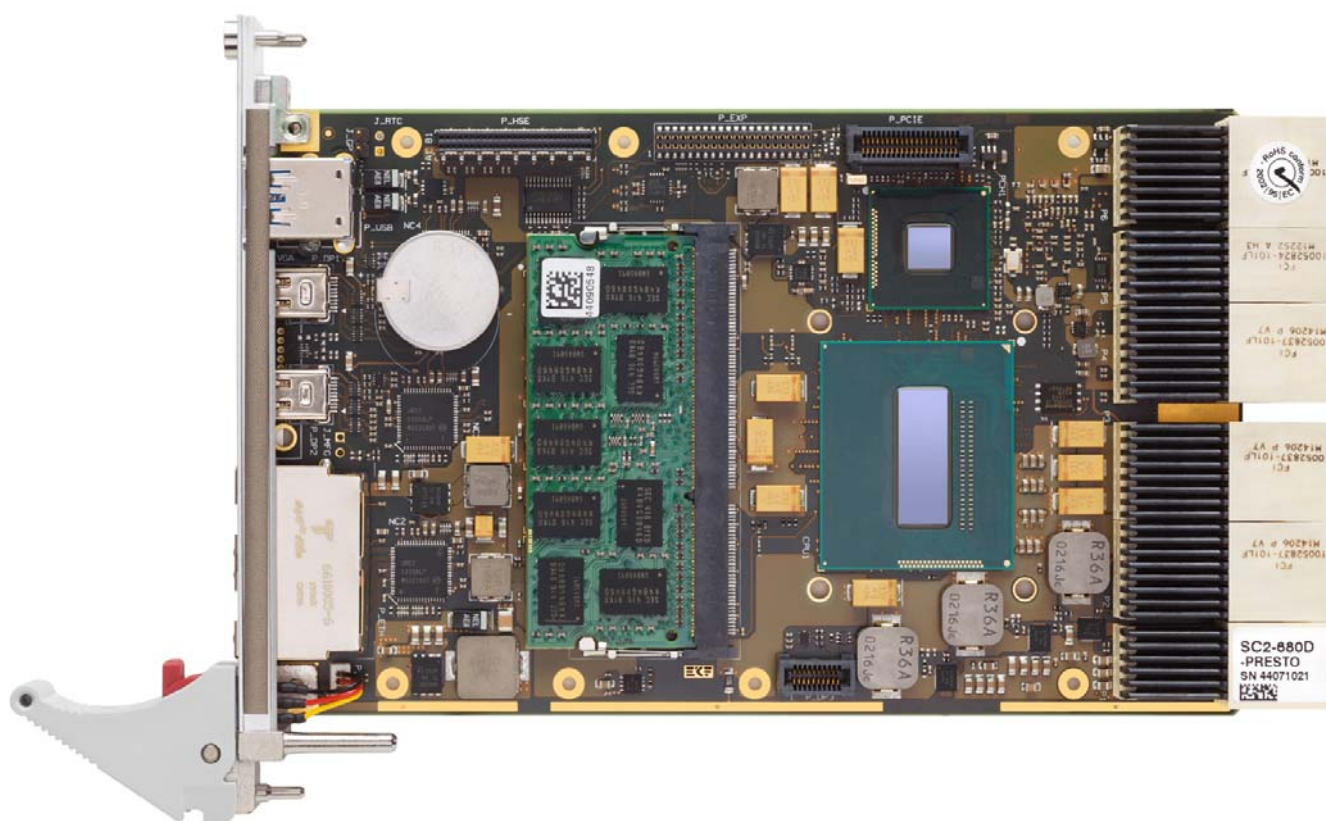



SC2-PRESTO



SC2-PRESTO



SC2-PRESTO w. C42-SATA Mezzanine Module 4HP Assembly



SC2-PRESTO w. C47-MSATA Mezzanine Module 4HP Assembly



SC2-PRESTO w. C41-CFAST Mezzanine Module 4HP Assembly



SC2-PRESTO w. C43-SATA Mezzanine Module 4HP Assembly



8HP Assembly SC2-PRESTO w. SCS-TRUMPET Mezzanine Side Card (2.5-Inch SATA SSD)



8HP Assembly SC2-PRESTO w. SCS-TRUMPET Side Card (Dual M.2 SATA SSD)

## CompactPCI® Serial

### System Slot Controller

The PICMG® *CompactPCI*® Serial specification defines a card slot system based on the modern high speed data-links PCI Express®, SATA, Ethernet and USB. The SC2-PRESTO, designed to act as a *CompactPCI*® Serial system slot controller, provides the resources of these interfaces. The backplane distributes them in the form of point to point connections to the peripheral slots.

The SC2-PRESTO allocates most but not all communication channels defined by *CompactPCI*® Serial on the backplane:

- ▶ Two PCIe Links x8, 2.5GT/s, 5GT/s or 8GT/s (Fat Pipes)
- ▶ Six PCIe Links x1, 2.5GT/s or 5GT/s
- ▶ Seven SATA Ports (6 x 6G, 1 x 3G)
- ▶ Two USB 3.0 Ports
- ▶ Six USB 2.0 Ports
- ▶ Two Gigabit Ethernet Ports

These resources will be distributed on a typical 9-slot *CompactPCI*® Serial backplane as follows:

SC2-PRESTO R.1 • Resources w. 1 + 8 Slots Backplane (System Slot Left)

P6	1	SYS	GBE (1-2)						
				GBE (1)					
P5				GBE (2)					
P4									
P3									
P2									
P1									

Backplane Resources SC2-PRESTO (System Slot Left)

[www.ekf.com/s/sc2/img/sc2\\_backplane.pdf](http://www.ekf.com/s/sc2/img/sc2_backplane.pdf)

© EKF • ekf.com



SC2-PRESTO R.1 • Resources w. 1 + 8 Slots Backplane (System Slot Right)

	①	②	③	④	⑤	⑥	⑦	⑧	⑨
							GbE (2)	GbE (1)	SYS GbE (1-2)
P6									CLK PE (1-8) 2 x PE (7-8) Gen2 2 Links x 1
P5									4 x PE (3-6) Gen2 4 Links x 1
P4	PER 8	PER 7	PER 6	PER 5	PER 4	PER 3	PER 2	PER 1	3 x SATA (PCH) 4 x SATA (RAID) 1 x USB3 (2) 2 x USB2 (5-6)
P3									PE Gen3 x 8 (2) PE Gen3 ½ x 8 (1) 2 x USB2 (3-4) I/O
P2									PE Gen3 ½ x 8 (1) 1 x USB3 (1) Sideband
P1	Peripheral Slot PE Gen2 x 1 SATA 6G (PCH)	Peripheral Slot PE Gen2 x 1 SATA 6G (PCH)	Peripheral Slot PE Gen2 x 1 SATA 6G (RAID) USB2	Peripheral Slot PE Gen2 x 1 SATA 6G (RAID) USB2	Peripheral Slot PE Gen2 x 1 SATA 6G (RAID) USB2	Peripheral Slot PE Gen2 x 1 SATA 6G (RAID) USB2	Fat Pipe Slot PE Gen3 x 8 SATA 3G (PCH) USB3	Fat Pipe Slot PE Gen3 x 8 USB3	SC2-PRESTO

© EKF • ekf.com

Backplane Resources SC2-PRESTO (System Slot Right)

[www.ekf.com/s/sc2/img/sc2\\_backplane.pdf](http://www.ekf.com/s/sc2/img/sc2_backplane.pdf)

## Peripheral Slot Operation

Beyond that the SC2-PRESTO is operable in periphery slots as well. In this case it acts as a satellite system, linked to other (processor-) boards by its backplane Ethernet connections. The other resources associated with the backplane like PCI Express, SATA or USB are not usable in this situation.

Some of the following, system slot dedicated control signals get an altered function or will be disconnected from the backplane:

- ▶ PWRBTN# (Connector P1 Pin C3) will be disconnected
- ▶ PWR\_FAIL# (Connector P1 Pin F3) becomes GA1
- ▶ PRST# (Connector P1 Pin H2) becomes RST# and will be disconnected
- ▶ WAKE# (Connector P1 Pin I2) will be disconnected
- ▶ SGPIO (Connector P1 Pins G3/H3/J3/K3) will be disconnected

One result of that is, that a SC2-PRESTO plugged into a peripheral slot will not get a reset even if the system controller forces the reset signal on the backplane to an active state.

## Board Hot-Plug

Hot-plug of the SC2-PRESTO is not supported, no matter whether it is working as a system controller or satellite board.



System Slot (Left) & Peripheral Slots

Related Documents *CompactPCI® Serial*

CompactPCI® Serial Concise Overview

[www.ekf.com/s/serial\\_concise.pdf](http://www.ekf.com/s/serial_concise.pdf)

CompactPCI® Serial All You Need to Know

[www.ekf.com/s/smart\\_solution.pdf](http://www.ekf.com/s/smart_solution.pdf)



SRS-4401-RACK for up to 8 Peripheral Slot Cards

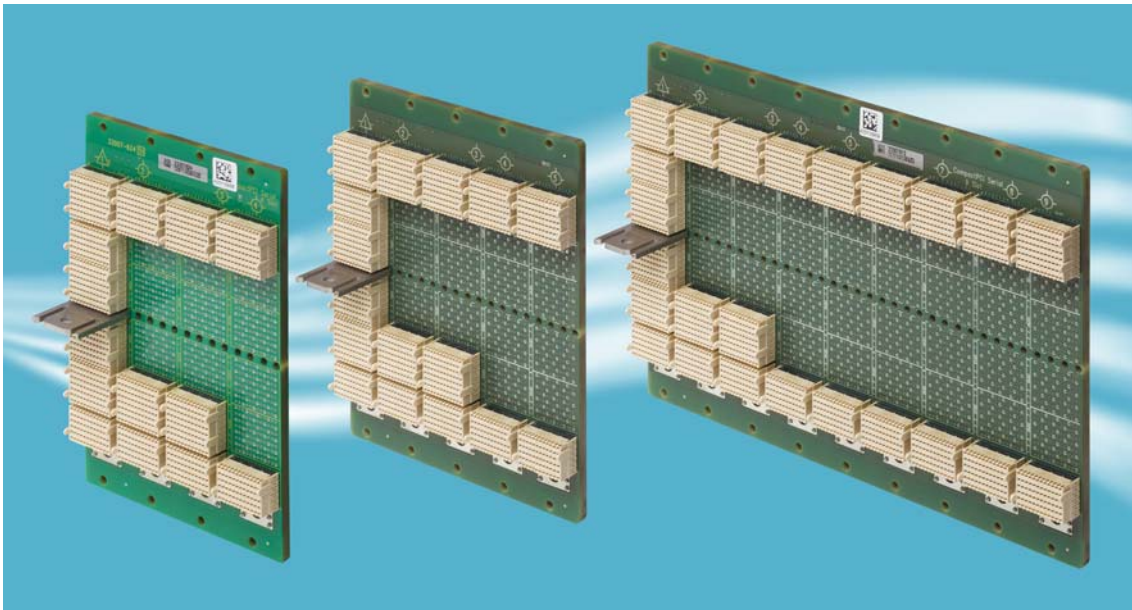

CompactPCI® Serial Backplanes

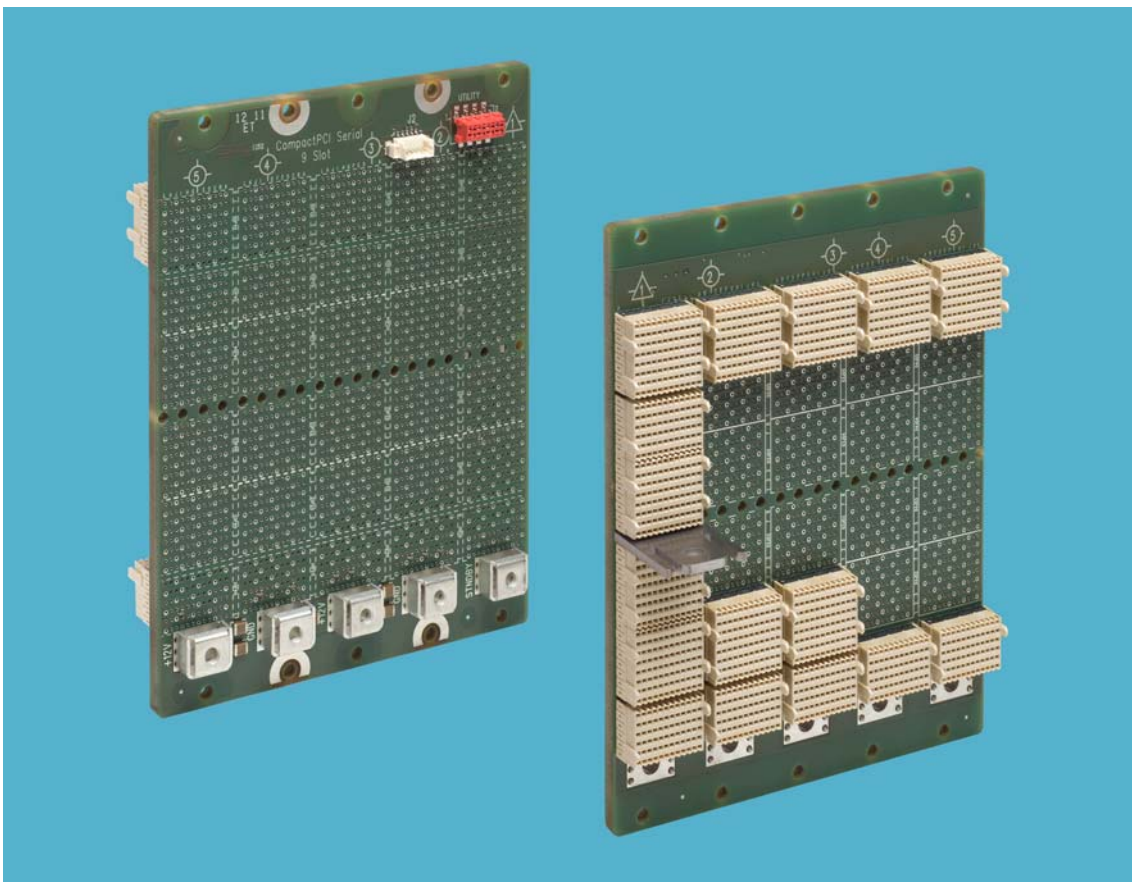

1 + 4 Slots CompactPCI® Serial Backplane



BLUBOXX Series Small Systems Rack



BLUBOXX Series for up to 4 Peripheral Slot Cards

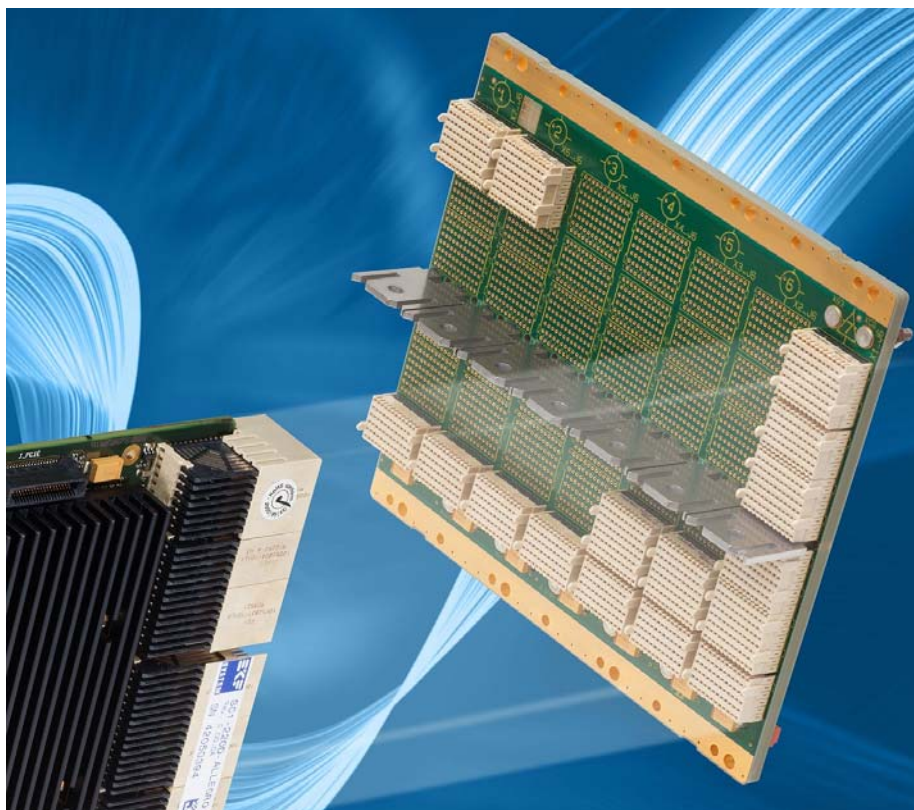

Sample Backplane w. System Slot Right Aligned



Custom Specific Racks 19-Inch

## Installing and Replacing Components

### Before You Begin

#### Warnings

The procedures in this chapter assume familiarity with the general terminology associated with industrial electronics and with safety practices and regulatory compliance required for using and modifying electronic equipment. Disconnect the system from its power source and from any telecommunication links, networks or modems before performing any of the procedures described in this chapter. Failure to disconnect power, or telecommunication links before you open the system or perform any procedures can result in personal injury or equipment damage. Some parts of the system can continue to operate even though the power switch is in its off state.



#### Caution

Electrostatic discharge (ESD) can damage components. Perform the procedures described in this chapter only at an ESD workstation. If such a station is not available, you can provide some ESD protection by wearing an antistatic wrist strap and attaching it to a metal part of the system chassis or board front panel. Store the board only in its original ESD protected packaging (antistatic bag and antistatic box) in case of returning the board to EKF for repair.



## Installing the Board

### Warning

This procedure should be done only by qualified technical personnel. Disconnect the system from its power source before doing the procedures described here. Failure to disconnect power, or telecommunication links before you open the system or perform any procedures can result in personal injury or equipment damage.

Typically you will perform the following steps:

- Switch off the system, remove the AC power cord
- Attach your antistatic wrist strap to a metallic part of the system
- Remove the board packaging, be sure to touch the board only at the front panel
- Identify the related *CompactPCI*® slot (peripheral slot for I/O boards, system slot for CPU boards, with the system slot typically most right or most left to the backplane)
- Insert card carefully (be sure not to damage components mounted on the bottom side of the board by scratching neighbored front panels)
- A card with onboard connectors requires attachment of associated cabling now
- Lock the ejector lever, fix screws at the front panel (top/bottom)
- Retain original packaging in case of return





## Removing the Board

### Warning

This procedure should be done only by qualified technical personnel. Disconnect the system from its power source before doing the procedures described here. Failure to disconnect power, or telecommunication links before you open the system or perform any procedures can result in personal injury or equipment damage.

Typically you will perform the following steps:

- Switch off the system, remove the AC power cord
- Attach your antistatic wrist strap to a metallic part of the system
- Identify the board, be sure to touch the board only at the front panel
- Unfasten both front panel screws (top/bottom), unlock the ejector lever
- Remove any onboard cabling assembly
- Activate the ejector lever
- Remove the card carefully (be sure not to damage components mounted on the bottom side of the board by scratching neighbored front panels)
- Store board in the original packaging, do not touch any components, hold the board at the front panel only



### Warning

Do not expose the card to fire. Battery cells and other components could explode and cause personal injury.



## EMC Recommendations



In order to comply with the CE regulations for EMC, it is mandatory to observe the following rules:

- The chassis or rack including other boards in use must comply entirely with CE
- Close all board slots not in use with a blind front panel
- Front panels must be fastened by built-in screws
- Cover any unused front panel mounted connector with a shielding cap
- External communications cable assemblies must be shielded (shield connected only at one end of the cable)
- Use ferrite beads for cabling wherever appropriate
- Some connectors may require additional isolating parts

## Recommended Accessories

Blind CPCI Front Panels	EKF Elektronik	Widths currently available (1HP=5.08mm): with handle 4HP/8HP without handle 2HP/4HP/8HP/10HP/12HP
Ferrit Bead Filters	Ask EKF	
Metal Shielding Caps	Ask EKF	

## Replacement of the Battery

When your system is turned off, a battery maintains the voltage to run the time-of-day clock and to keep the values in the CMOS RAM. The battery should last during the lifetime of the SC2-PRESTO.

However, some versions of SC2-PRESTO are delivered with a battery holder which makes it possible for the user to replace the coin cell. Use a BR2032 cell as replacement part to ensure an extended temperature range. Be careful when removing the old cell and inserting the new one.

For boards with a soldered battery the old battery must be desoldered, and the new one soldered. We suggest that you send back the board to EKF for battery replacement.

## Warning

Danger of explosion if the battery is incorrectly replaced or shorted. Replace only with the same or equivalent type. Do not expose a battery to fire.

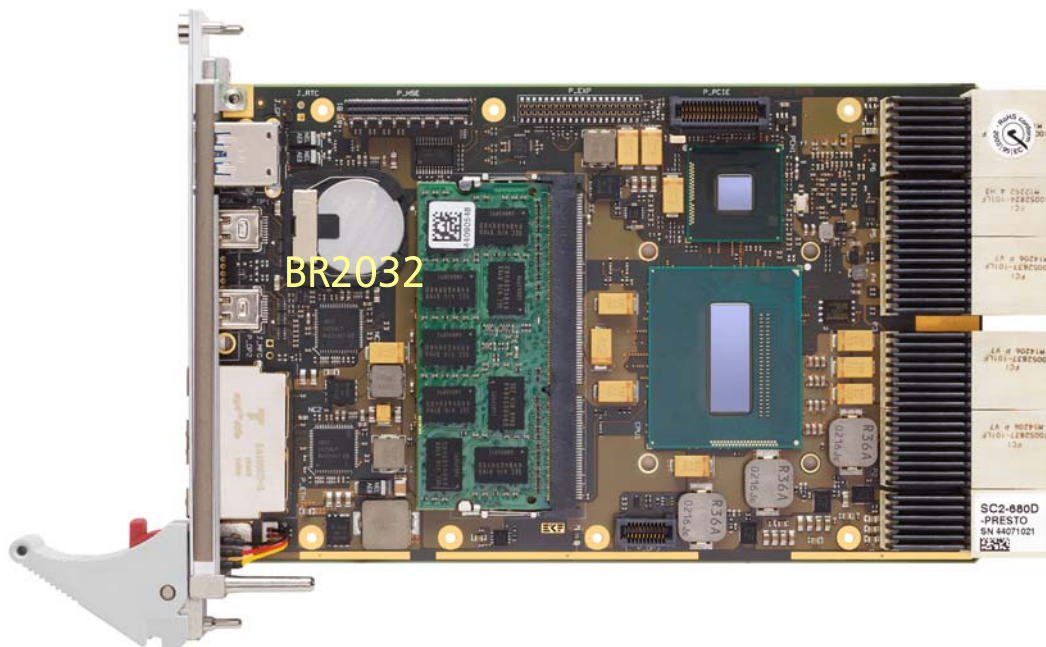

## Technical Reference

### Local PCI Devices

The following table shows the on-board PCI devices and their location within the PCI configuration space. Several devices are part of the processor and platform controller hub QM87.

Bus #	Device #	Function #	Vendor ID	Device ID	Description
0	0	0	0x8086	0x0C04	Processor Host Bridge/DRAM Controller
0	1	0	0x8086	0x0C01	Processor PCI Express Controller
0	1	1	0x8086	0x0C05	Processor PCI Express Controller
0	2	0	0x8086	0x0416	Processor Integrated Graphics Device
0	3	0	0x8086	0x0C0C	Audio Controller
0	20	0	0x8086	0x8C31	USB xHCI Controller
0	22	0	0x8086	0x8C3A	Intel ME Interface #1
0	22	1	0x8086	0x8C3B	Intel ME Interface #2
0	22	2	0x8086	0x8C3C	Intel ME IDE Redirection
0	22	3	0x8086	0x8C3D	Intel ME Keyboard Text Redirection
0	25	0	0x8086	0x153A	PCH Gigabit LAN NC1 (i217LM)
0	26	0	0x8086	0x8C2D	USB EHCI Controller #2
0	27	0	0x8086	0x8C20	Intel High Definition Audio Controller
0	28	0	0x8086	0x8C10	PCH PCI Express Port 1
0	28	3	0x8086	0x8C16	PCH PCI Express Port 4
0	28	4	0x8086	0x8C18	PCH PCI Express Port 5
0	29	0	0x8086	0x8C26	USB EHCI Controller #1
0	31	0	0x8086	0x8C4F	LPC Bridge
0	31	2	0x8086	0x8C01 0x8C03 0x1E07	SATA: Non-AHCI/Non-RAID (Ports 0-3) <sup>1)</sup> SATA: AHCI Mode <sup>1)</sup> SATA: RAID Capable <sup>2)</sup>
0	31	3	0x8086	0x8C22	SMBus Controller
0	31	5	0x8086	0x8C09	SATA: Non-AHCI/Non-RAID (Ports 4/5)
0	31	6	0x8086	0x8C24	Thermal Controller
1 <sup>3)</sup>	00	0	0x1B4B	0x9230	SATA Host Controller (88SE9230)
2 <sup>3)</sup>	00	0	0x8086	0x157B	Ethernet Controller NC2 (i210IT)
3 <sup>3)</sup>	00	0	0x10B5	0x8618	PCIe Switch Root Port (PEX8618)
4 <sup>3)</sup>	01,02,04 ...	0	0x10B5	0x8618	PCIe Switch Downstream Ports (PEX8618)
5 <sup>3)</sup>	00	0	0x8086	0x157B	Ethernet Controller NC3 (i210IT)
6 <sup>3)</sup>	00	0	0x8086	0x157B	Ethernet Controller NC4 (i210IT)

<sup>1)</sup> Depends on BIOS settings.

<sup>2)</sup> Depending on BIOS settings different RAID modes may lead to other Device IDs.

<sup>3)</sup> Bus number can vary depending on the PCI enumeration schema implemented in BIOS.

**Physical Routing (Bus Numbering)**  
of the PEX 8618 PCIe Switch Ports/Lanes to the CompactPCI® Serial Backplane

PEX 8618 Port	PEX 8618 Lane	CPU (System Slot) Connector	Targeted Backplane Slot
2	4	P4 3_PE	4 of 9
10	5	P4 4_PE	5 of 9
12	6	P4 5_PE	6 of 9
14	7	P4 6_PE	7 of 9
13	14	P5 7_PE	8 of 9
15	15	P5 8_PE	9 of 9

Please note that the PEX 8618 ports are not assigned to backplane slots in an ascending order with respect to the PCIe switch ports 13/14. The BIOS PCI bus enumeration algorithm as of current (2018-02) follows exactly the PEX 8618 port number, not the lane number. Since this may cause some irritation, we are currently considering a port swapping within future BIOS releases - check for updates regularly.

## Local SMB Devices

The SC2-PRESTO contains devices that are attached to the System Management Bus (SMBus). These are the SPD EEPROMs for the on-board memory or the possibly plugged SODIMM, a general purpose serial EEPROM, a supply voltage/temperature controlling device and a set of board control and status registers. Additional devices may be connected to the SMBus via the *CompactPCI*® Serial backplane signals I<sup>2</sup>C\_SCL (P1 B2) and I<sup>2</sup>C\_SDA (P1 B3), or pins 29/30 of the mezzanine expansion connector P-EXP.

Address	Description
0x58	Hardware Monitor/Memory Down Temperature Sensor (LM87)
0x5C	Board Control/Status
0xA0	SPD of On-board Memory
0xA4	SPD of SODIMM
0xAE	General Purpose EEPROM

## Hardware Monitor LM87

Attached to the SMBus, the SC2-PRESTO is provided with a hardware monitor (LM87). This device is capable to observe the board and on-board memory temperatures, as well as several supply voltage rails with a resolution of 8 bit. The following table shows the mapping of the voltage inputs of the LM87 to the corresponding supply voltages of the SC2-PRESTO:

Input	Source	Resolution	Register
AIN1	Processor Core Voltage	9.8mV	0x28
AIN2	+1.5V	9.8mV	0x29
VCCP1	+1.35V	14.1mV	0x21
VCCP2/D2-	+1.8V	14.1mV	0x25
+2.5V/D2+	+1.05V	13mV	0x20
+3.3V	+3.3V	17.2mV	0x22
+5V	+5V	26mV	0x23
+12V	+12V	62.5mV	0x24
D1 +/D1-	Memory Down absolute Temperature	1°C	0x26
Local TEMP	SC2 Surface Temperature	1°C	0x27

Beside the continuous measuring of temperatures and voltages the LM87 may compare these values against programmable upper and lower boundaries. As soon as a measurement violates the allowed value range, the LM87 can request an interrupt via the GPI13 input of the QM87 PCH (which may result in a system management interrupt).

## Board Control and Status Registers (BCSR)

A set of board control and status registers allow to program special features on the SC2-PRESTO:

- Assert a full reset
- Control activity of front panel reset and power event button
- Program time-outs and trigger a watchdog
- Get access to two LEDs in the front panel
- Get power fail and watchdog status of last board reset

The register set consists of five registers located on the SMBus at Device ID=0x5c on the following addresses:

- 0xA0: CMD\_CTRL0\_WR: Write to Control Register 0 (Write-Only)
- 0xA1: CMD\_CTRL0\_RD: Read from Control Register 0 (Read-Only)
- 0xB0: CMD\_STAT0\_WR: Write to Status Register 0 (Write-Clear)
- 0xB1: CMD\_STAT0\_RD: Read from Status Register 0 (Read-Only)
- 0xB2: CMD\_STAT1\_WR: Write to Status Register 1 (Write-Clear)
- 0xB3: CMD\_STAT1\_RD: Read from Status Register 1 (Read-Only)
- 0xC1: CMD\_PLDREV\_RD: Read from PLD Revision Register (Read-Only)

To prevent malfunction accesses to the registers should be done by SMBus “Byte Data” commands. Further writes to read-only or reads to write-only registers should be omitted.



## Write/Read Control Register 0

Write: SMBus Address 0xA0

Default after reset: 0x00

Read: SMBus Address 0xA1

Bit	Description CMD_CTRL0
7	<b>GPLED</b> 0=Green part of the front panel LED GP is off (Default) 1=Green part of the front panel LED GP is on
6	<b>FPDIS</b> 0=Enable the front panel handle switch (Default) 1=Disable the front panel handle switch
5	<b>FERP#</b> 0=The front panel handle switch generates a power event (Default) 1=The front panel handle switch generates a system reset
4:3	<b>WDGT0:WDGT1</b> Maximum Watchdog retrigger time: 0:0    2 sec 1:0    10 sec 0:1    50 sec 1:1    250 sec
2	<b>WDGTRG</b> Retrigger Watchdog. Any change of this bit will retrigger the watchdog. After a system reset the watchdog is in an inactive state. The watchdog is armed on the 1 <sup>st</sup> edge of this bit.
1	<b>PGLED</b> 0=Red part of the front panel LED PG is off (Default) 1=Red part of the front panel LED PG is blinking
0	<b>SRES</b> 0=Normal operation (Default) 1=A full system reset is performed

## Read/Clear Status Register 0

Write: SMBus Address 0xB0

Read: SMBus Address 0xB1

Bit	Description CMD_STAT0
7	<b>PF18S</b> 0=Normal operation 1=Last system reset may be caused by a power failure of the +V1.8S voltage regulator
6	<b>PF15S</b> 0=Normal operation 1=Last system reset may be caused by a power failure of the +V1.5S voltage regulator
5	<b>PF135S</b> 0=Normal operation 1=Last system reset may be caused by a power failure of the +V1.35S voltage regulator
4	<b>RESERVED</b> Always read as 0
3	<b>PF105M</b> 0=Normal operation 1=Last system reset may be caused by a power failure of the +V1.05M voltage regulator
2	<b>PF105S</b> 0=Normal operation 1=Last system reset may be caused by a power failure of the +V1.05S voltage regulator
1	<b>RESERVED</b> Always read as 0
0	<b>PFVRC</b> 0=Normal operation 1=Last system reset may be caused by a power failure of the CPU voltage regulator

The bits in this register are sticky, i.e. their state will be kept even if a system reset occurs. To clear the bits a write to the register with arbitrary data may be performed.

## Read/Clear Status Register 1

Write: SMBus Address 0xB2

Read: SMBus Address 0xB3

Bit	Description CMD_STAT1
7	<b>WDGARM</b> 0=Normal operation 1=The watchdog is armed and has to be retrigged within its time-out period
6	<b>WDGRST</b> 0=Normal operation 1=Last system reset may be caused by a watchdog time-out
5	<b>WDGHT</b> 0=Normal operation 1=The watchdog already has elapsed half of its time-out period
4	<b>PF5PS</b> 0=Normal operation 1=Last system reset may be caused by a power failure of the +V5PS voltage regulator
3	<b>PF5S</b> 0=Normal operation 1=Last system reset may be caused by a power failure of the +V5S voltage regulator
2	<b>PF33M</b> 0=Normal operation 1=Last system reset may be caused by a power failure of the +V3.3M voltage regulator
1	<b>PF33A</b> 0=Normal operation 1=Last system reset may be caused by a power failure of the +V3.3A voltage regulator
0	<b>PF33S</b> 0=Normal operation 1=Last system reset may be caused by a power failure of the +V3.3S voltage regulator

Except of WDGHT and WDGARM the bits in this register are sticky, i.e. their state will be kept even if a system reset occurs. To clear the bits a write to the register with arbitrary data may be performed.

## Read PLD Revision Register

Write: Not allowed

Read: SMBus Address 0xC1

Bit	Description CMD_PLDREV
7:0	<b>PLDREV</b> Read PLD Revision Number

## GPIO Usage

## GPIO Usage QM87 PCH

GPIO Usage QM87 PCH				
GPIO	Type	Voltage <sup>1)</sup>	Function	Description
0	I	+V3.3S	THRM_ALERT#	Monitoring of processor PROCHOT#
1	I	+V3.3S	EXP_SMI#	Expansion Interface SMI Request (P-EXP Pin 15)
2-3	I	+V3.3S	N/A	Not used on SC2 (pulled via resistors to GND)
4	I	+V3.3S	CPCI_PWR_FAIL#	Sense <i>CompactPCI</i> ® Serial Power Failure Line PWR_FAIL#
5	I	+V3.3S	PM_MEMTS#	Memory Thermal Sensor Event
6	I	+V3.3S	N/A	Not used on SC2 (pulled via resistor to GND)
7	I	+V3.3S	GP_JUMP#	Reset UEFI BIOS Setup to Factory Defaults, Jumper J-GP
8	O	+V3.3A	CPCI_SYSEN#	Sense <i>CompactPCI</i> ® System Slot Enable Line SYSEN#
9	I	+V3.3A	USB_OC5#	USB P-HSE Port 2 Overcurrent Detect
10	I	+V3.3A	USB_OC6#	USB P-HSE Port 3 or 4 Overcurrent Detect
11	I	+V3.3A	NV_GP1	Non-Volatile Jumper NV-GP1
12	O	+V3.3A	NC1_ENABLE	Enable Ethernet Controller NC1
13	I	+V3.3A	HM_INT#	Hardware Monitor LM87 Interrupt Line
14	I	+V3.3A	USB_OC7#	USB P-EXP Port 1 or 2 Overcurrent Detect
15	O	+V3.3A	N/A	Not connected on SC2
16	O	+V3.3S	SE_SYS_WP	General Purpose Serial EEPROM Write Protection
17	I	+V3.3S	PPSM_EN	Connect IEEE 1588 PPS/PPM to J-GP and <i>CompactPCI</i> ® P1 LOW: PPS/PPM disconnected from J-GP and P1 HIGH: PPS/PPM connected to J-GP and P1
18	O	+V3.3S	GP_LED_RED	General Purpose Red LED Control (via PLD)
19	I	+V3.3S	N/A	Not used on SC2 (pulled via resistor to +3.3V)
20	I	+V3.3S	PCIE_CLK_REQ2#	<i>CompactPCI</i> ® Clock Request Slot 5 (P5 A6: 5_PE_CLKE#)
21	I	+V3.3S	N/A	Not used on SC2 (pulled via resistor to GND)
22	O	+V3.3S	SGPIO_CLOCK	<i>CompactPCI</i> Serial GPIO Bus CLOCK (P1 J3: SATA_SCL)
23	I	+V3.3S	N/A	Not connected on SC2
24	O	+V3.3A	USB_POWER1#	USB Front Panel Right Port Power Enable
25	I	+V3.3A	PCIE_CLK_REQ3#	<i>CompactPCI</i> ® Clock Request Slot 6 (P5 D6: 6_PE_CLKE#)
26	I	+V3.3A	PCIE_CLK_REQ4#	<i>CompactPCI</i> ® Clock Request Slot 4 (P5 L5: 4_PE_CLKE#)
27	I	+V3.3A	NC1_WAKE#	Ethernet Controller NC1 WAKE#
28	O	+V3.3A	USB_POWER2#	USB Front Panel Left Port Power Enable
29	O	+V3.3A	N/A	Not connected on SC2
30-31	I	+V3.3A	N/A	Not used on SC2 (pulled via resistors to +3.3V)
32	I	+V3.3S	N/A	Not used on SC2 (pulled via resistor to +3.3V)
33	O	+V3.3S	N/A	Not connected on SC2
34	O	+V3.3S	EXP_SMB_EN	Connect SMBus on P-EXP to local SMBus LOW: P-EXP disconnected from SMBus HIGH: P-EXP connected to SMBus

GPIO Usage QM87 PCH				
GPIO	Type	Voltage <sup>1)</sup>	Function	Description
35	O	+V3.3S	CPCI_SMB_EN	Connect SMBus on <i>CompactPCI</i> Serial to local SMBus LOW: CPCI Backplane disconnected from SMBus HIGH: CPCI Backplane connected to SMBus
36	I	+V3.3S	N/A	Not used on SC2 (pulled via resistor to GND)
37	I	+V3.3S	N/A	Not used on SC2 (pulled via resistor to +3.3V)
38	O	+V3.3S	SGPIO_LOAD	<i>CompactPCI</i> Serial GPIO Bus LOAD (P1 K3: SATA_SL)
39	O	+V3.3S	SGPIO_OUT	<i>CompactPCI</i> Serial GPIO Bus DATAOUT (P1 H3: SATA_SDO)
40	I	+V3.3A	USB_OC1#	USB Front Panel Left Port Overcurrent Detect
41	O	+V3.3A	ENABLE_NC3	Enable Ethernet Controller NC3
42	O	+V3.3A	ENABLE_NC4	Enable Ethernet Controller NC4
43	I	+V3.3A	USB_OC4#	USB P-HSE Port 1 Overcurrent Detect
44	I	+V3.3A	PCIE_CLK_REQ5#	<i>CompactPCI</i> ® Clock Request Slot 8 (P5 J6: 8_PE_CLKE#)
45	I	+V3.3A	PCIE_CLK_REQ6#	<i>CompactPCI</i> ® Clock Request Slot 7 (P5 G6: 7_PE_CLKE#)
46	I	+V3.3A	PCIE_CLK_REQ7#	<i>CompactPCI</i> ® Clock Request Slot 3 (P5 I5: 3_PE_CLKE#)
47	I	+V3.3A	PEG_A_CLK_RQ#	<i>CompactPCI</i> ® Clock Request Slot 1 (P5 C5: 1_PE_CLKE#)
48-49	I	+V3.3S	N/A	Not used on SC2 (pulled via resistors to GND)
50	I	+V3.3S	HWREV	PCB Revision Code HWREV[2:0]: GPIO[54/52/50]    000    001    010    ...    111 Revision    0    1    2    ...    7
51	O	+V3.3S	N/A	Not used on SC2 (pulled via resistor to +3.3V)
52	I	+V3.3S	HWREV	PCB Revision Code HWREV[2:0], see GPIO50
53	O	+V3.3S	N/A	Not connected on SC2
54	I	+V3.3S	HWREV	PCB Revision Code HWREV[2:0], see GPIO50
55	O	+V3.3S	ENABLE_NC2	Enable Ethernet Controller NC2
56	I	+V3.3A	PEG_B_CLK_RQ#	<i>CompactPCI</i> ® Clock Request Slot 2 (P5 F5: 2_PE_CLKE#)
57	I	+V3.3A	N/A	TPM2.0 Physical Present Pin
58	I	+V3.3A	N/A	Not used on SC2 (pulled via resistor to +3.3V)
59	I	+V3.3A	USB_OC0#	USB Front Panel Right Port Overcurrent Detect
60	I	+V3.3A	N/A	Not used on SC2 (pulled via resistor to +3.3V)
61-62	O	+V3.3A	N/A	Not connected on SC2
63	O	+V3.3A	SLP_S5#	Multiplexed with chipset internal function
64	O	+V3.3S	CLKOUT_FLEX1	14.318MHz Clock Source
65-67	O	+V3.3A	N/A	Not connected on SC2
68-71	I	+V3.3S	BOARD_CFG	Board Configuration Jumpers BOARD_CGF[0:3]
72	I	+V3.3A	N/A	Not used on SC2 (pulled via resistor to +3.3V)
73	I	+V3.3A	PCIE_CLK_REQ0#	Ethernet Controller NC1 Clock Request
74-75	I	+V3.3A	N/A	Not used on SC2 (pulled via resistors to +3.3V)

<sup>1)</sup> S=Core Voltage (active in state S0 only), A=Standby Voltage

## Configuration Jumpers

### Configuration PCI Express Switch (DS-P)

The link width and transfer rate of the PCI Express interfaces attached to the local expansion connector P-PCIE is configurable by two DIP switches (DS-P) located on the backside of the SC2-PRESTO. Note that changes in PCIe link configuration are honoured by the board not before a system reset was performed.

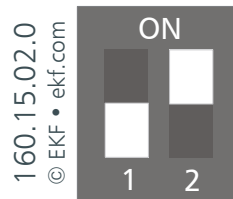

**DS-P**

DS-P		PCIe Link Width		
1	2	PCIe Switch Upstream	CPCI Serial <sup>1)</sup>	P-PCIE
OFF	OFF	4 Lanes @ 5GT/s	6 Links x 1 Lane @ 5GT/s	4 Links x 1 Lane @ 5GT/s
ON	OFF	4 Lanes @ 5GT/s	6 Links x 1 Lane @ 5GT/s	1 Link x 4 Lanes @ 5GT/s
OFF	ON	4 Lanes @ 2.5GT/s	6 Links x 1 Lane @ 2.5GT/s	4 Links x 1 Lane @ 2.5GT/s
ON	ON	4 Lanes @ 2.5GT/s	6 Links x 1 Lane @ 2.5GT/s	1 Link x 4 Lanes @ 2.5GT/s

<sup>1)</sup> Consists to the non fat pipe slots, generally periphery slots 3 to 8.

When the port on P-PCIE is configured as single link, the PCIe switch may size down the link width to x2 or x1 by auto-negotiation.

The following table shows the factory settings of DS-P with different side boards mounted to the SC2-PRESTO:

Side Board	DS-P		PCIe Link Width
	1	2	P-PCIE
None	OFF	OFF	4 Links x 1 Lane @ 5GT/s
CCI-RAP	OFF	OFF	4 Links x 1 Lane @ 5GT/s
CCK-MARIMBA	ON	OFF	1 Link x 4 Lanes @ 5GT/s
CCL-CAPELLA	ON	OFF	1 Link x 4 Lanes @ 5GT/s
PCS-BALLET	OFF	OFF	4 Links x 1 Lane @ 5GT/s
SCS-TRUMPET	OFF	OFF	4 Links x 1 Lane @ 5GT/s

## Loading UEFI BIOS Setup Defaults/IEEE 1588 Pulse per Second (J-GP)

The jumper J-GP may be used to reset the UEFI BIOS configuration settings to a default state. The UEFI BIOS on SC2-PRESTO stores most of its settings in an area within the BIOS flash, e.g. the actual boot devices. Using the jumper J-GP is only necessary, if it is not possible to enter the setup of the BIOS. To reset the settings mount a jumper on J-GP and perform a system reset. As long as the jumper is stuffed the BIOS will use the default configuration values after any system reset. To get normal operation again, the jumper has to be removed.

There is also an alternate function available on J-GP. Pin 1 of this jumper carries a Pulse per Second (PPS) signal according the IEEE 1588 specification when enabled by UEFI BIOS settings. A wire may be connected to trigger events on external devices.

NOTE: The PPS signal can be gripped at the CompactPCI® Serial connector P1 pin J3 (SATA-SCL) also.



J-GP

J-GP	Function
Jumper Removed <sup>1)</sup>	Normal operation
Jumper Installed	BIOS configuration reset performed

<sup>1)</sup> This setting is the factory default

## Manufacturer Mode Jumper (J-MFG)

The jumper J-MFG is used to bring the board into the manufacturer mode. This is necessary only on board production time and should not be used by customers. For normal operation the jumper should be removed. The pin header J-MFG is not stuffed on the SC2-PRESTO by default.



J-MFG

J-MFG	Function
Jumper Removed <sup>1)</sup>	Normal operation
Jumper Installed	Entering Manufacturer Mode

<sup>1)</sup> This setting is the factory default

## RTC Reset (J-RTC)

The jumper J-RTC may be used to reset certain register bits of the battery backed RTC core within the PCH QM87. This can be necessary under rare conditions (e.g. battery undervoltage), if the CPU fails to enter the BIOS POST after power on. Note that installing of jumper J-RTC will neither set UEFI BIOS Setup to EKF Factory Defaults nor resets the time and date register values of the RTC (Real Time Clock). To reset the RTC core the board must be removed from the system rack. Short-circuit the pins of J-RTC for about 1 sec. Thereafter reinstall the board to the system and switch on the power. It is important to accomplish the RTC reset while the board has no power. The pin header J-RTC is not stuffed on the SC2-PRESTO by default.



J-RTC

J-RTC	Function
Jumper Removed <sup>1)</sup>	Normal operation
Jumper Installed	RTC reset performed

<sup>1)</sup> This setting is the factory default.



## Connectors

### Caution

Some of the internal connectors provide operating voltage (3.3V, 5V and 12V) to devices inside the system chassis, such as internal peripherals. Not all of these connectors are short circuit protected. Do not use these internal connectors for powering devices external to the computer chassis. A fault in the load presented by the external devices could cause damage to the board, the interconnecting cable and the external devices themselves.

### Front Panel Connectors

With respect to the video connector, the SC2-PRESTO is available in two flavours, either dual mDP or VGA.

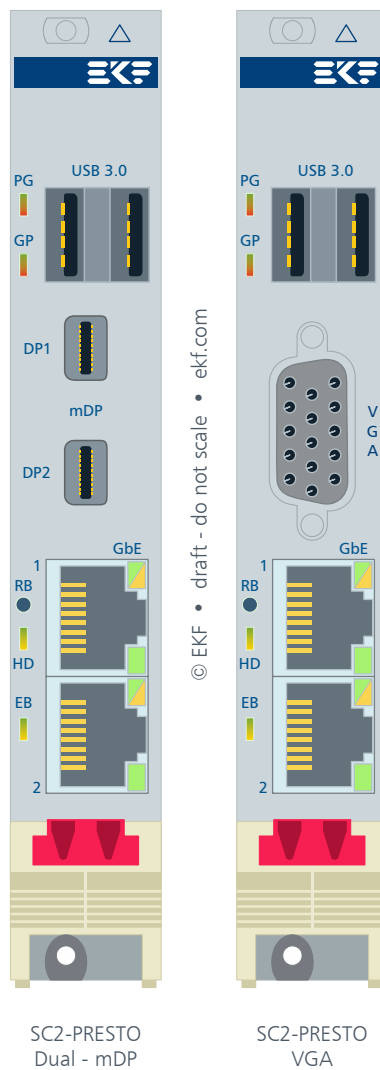

### Sample Front Panel Options 8HP

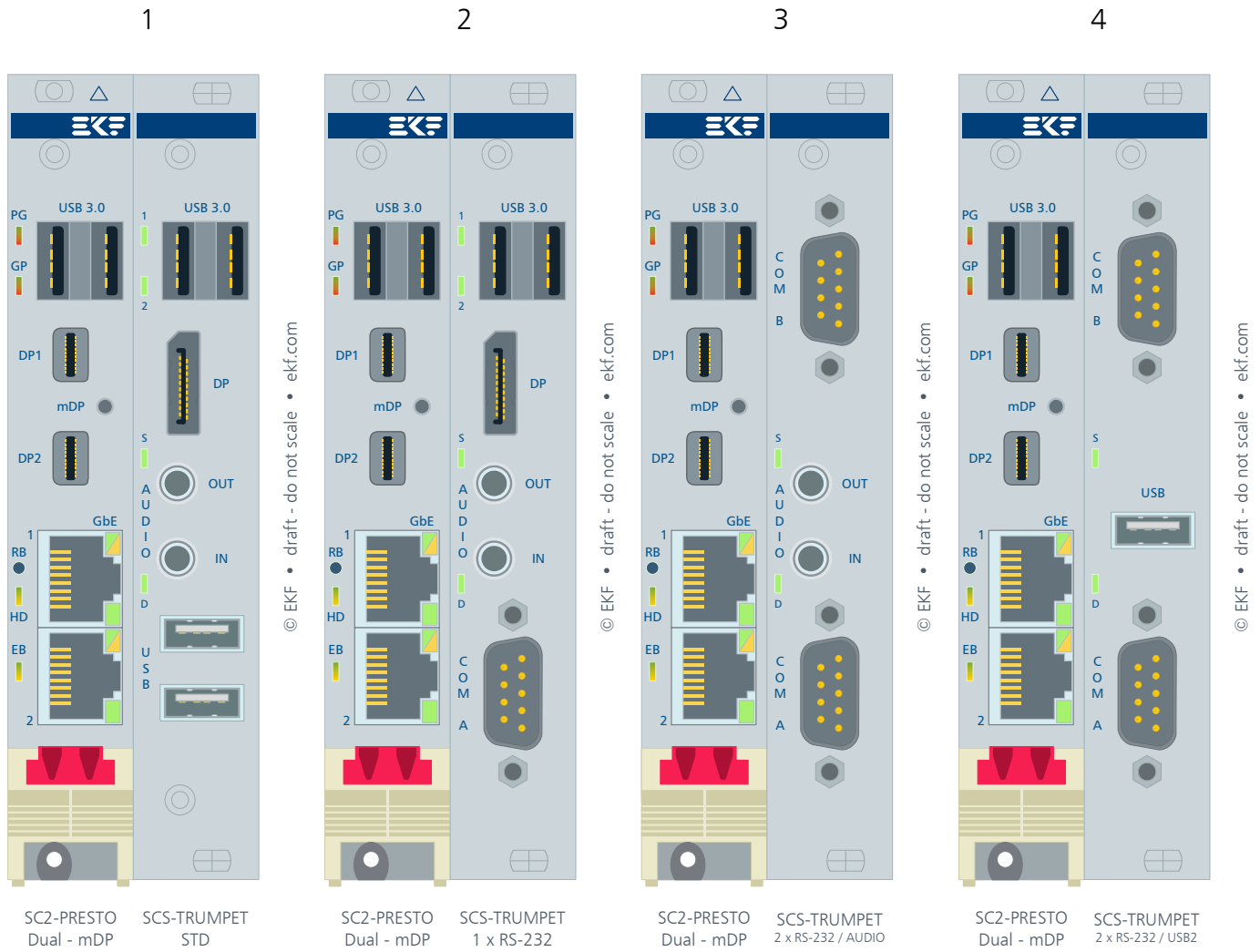

1. Typical assembly, dual-USB 3.0, DisplayPort, 3.5mm stereo audio in/out, 2 x USB 2.0
2. Bottom RS-232 male D-Sub 9-pin (COM-A) replaces two USB 2.0 jacks
3. Top RS-232 male D-Sub 9-pin (COM-B) replaces dual-USB 3.0 and DisplayPort connectors
4. Center USB 2.0 receptacle replaces both 3.5mm stereo audio jacks

Sample Front Panel Options 12HP

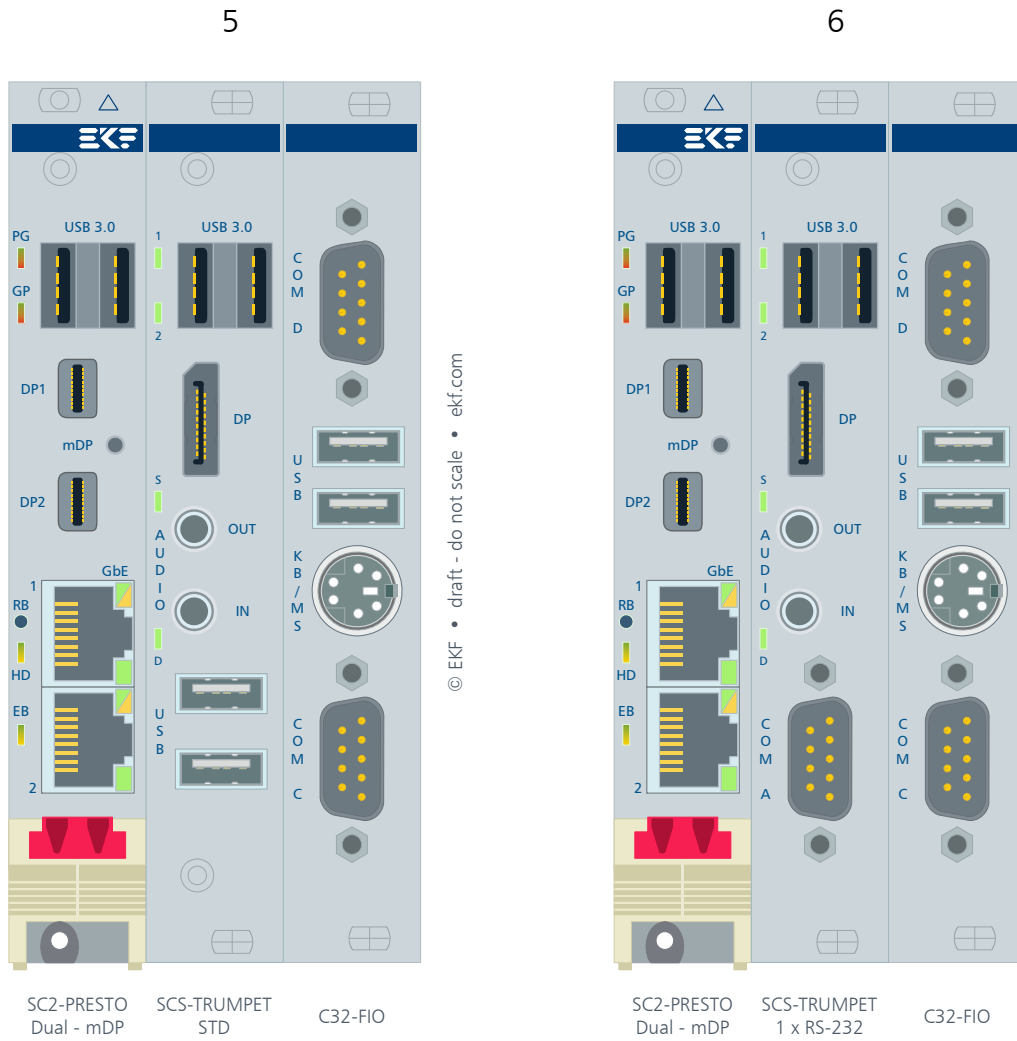

5. Dual-USB 3.0, DisplayPort, 3.5mm stereo audio in/out, 4 x USB 2.0, 2 x RS-232 (COM-C/D)

6. Dual-USB 3.0, DisplayPort, 3.5mm stereo audio in/out, 2 x USB 2.0, 3 x RS-232 (COM-A/C/D)

## DisplayPort Connectors

The Intel® Core™ processors used on SC2-PRESTO are equipped with an integrated graphics controller, which supports DisplayPort and DVI interfaces permitting simultaneous independent operation of up to three displays. Two DP receptacles are available from the SC2-PRESTO front panel, as mDP (Mini DisplayPort) connectors, which is a space saving alternate to the standard DP connector and is also specified by the VESA.

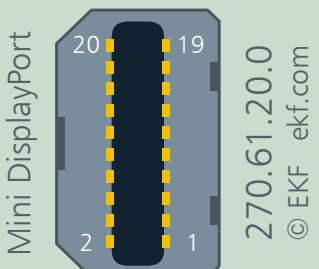
Mini DisplayPort P-DP1/2				
	20	PWR <sup>1)</sup>	19	GND
	18	AUX_CH(N)	17	LANE2(N)
	16	AUX_CH(P)	15	LANE2(P)
	14	GND	13	GND
	12	LANE3(N)	11	LANE1(N)
	10	LANE3(P)	9	LANE1(P)
	8	GND	7	GND
	6	CONFIG2 (GND)	5	LANE0(N)
	4	CONFIG1	3	LANE0(P)
	2	Hot Plug Detect	1	GND

<sup>1)</sup> +3.3V via 0.5A current-limited electronic power switch. This voltage is switched on in S0 state only.

Most DisplayPort monitors come with the standard DP connector, hence requiring a mDP to DP cable assembly for use with the SC2-PRESTO. For attachment of either a classic style analog RGB monitor, DVI or HDMI type display to the P-DP1/2 receptacles, there are both adapters and also adapter cables available.

Specified by the VESA DisplayPort connector standard is a dedicated power pin 20 (+3.3V 0.5A). Both the GPU (source side) and a DP monitor (sink side) must provide power via this pin. A VESA specified standard DisplayPort cable however should not connect the pins 20 of both cable ends, in order to avoid a back driving conflict. Fortunately the SC2-PRESTO takes care about this situation. Nevertheless, before ordering DP cable assemblies, verify the associated wiring diagram.

Sample VESA Compliant Mini DisplayPort Cable Assemblies	
2.0m Mini DisplayPort (mDP) to DisplayPort (DP) plug to plug cable assembly, VESA compliant	
EKF Part. #270.66.2.02.0	
Astron	T2M2M20020-R
Molex	0687850003
Roline	1045636
Wieson	G9858

## Screw Locking Option for mDP Connectors

Opposite to the Standard DisplayPort cable connectors, mDP connectors are not provided with a latching device. For rugged applications with need for a connector locking mechanism, EKF offers two methods of fixing.

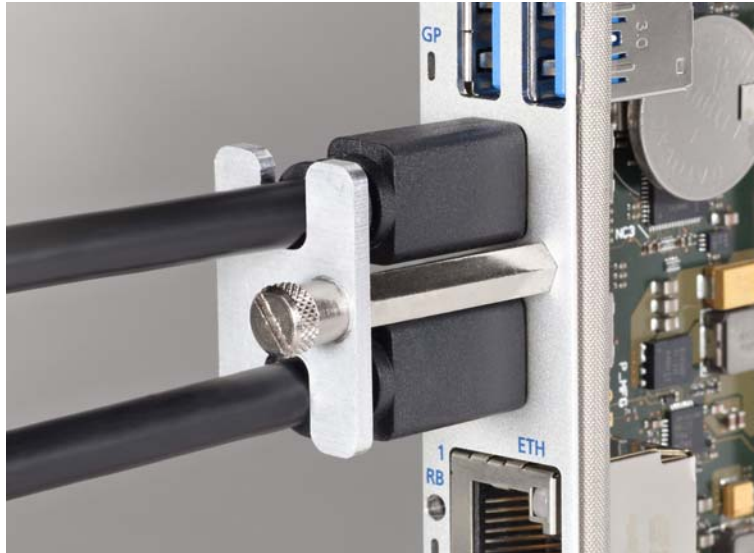

Option Screw-Lock Plate for mDP Cable Connectors

1. The front panel is provided with a threaded hole for fixing a removable H-shape retainer plate, which is available from EKF as accessory (image above).
2. As an alternate, the customer can use cable assemblies with screw-locked mDP connectors (image below). The front panel has to be modified however for this solution (two threaded holes in addition, please specify when ordering).



Screw-Locked mDP Connector Cable Assembly (Delock)

A third DisplayPort video output is available when combining the SC2-PRESTO with the mezzanine side card SCS-TRUMPET or PCS-BALLET. The standard DP connector provided on these side cards is provided with latches, which may be preferred for some applications.



SC2-PRESTO w. SCS-TRUMPET



SC2-PRESTO w. PCS-BALLET Side Card & 2.5-Inch SSD, 8HP



SC2-PRESTO w. PCS-BALLET C32-FIO C20-SATA, 12HP

## VGA Video Connector

As an option, the SC2-PRESTO can be equipped with a legacy VGA connector (High-Density D-Sub 15-position female connector). The connector VGA replaces the two Mini DisplayPort receptacles, and the digital video interface therefore is not available concurrently with this option.

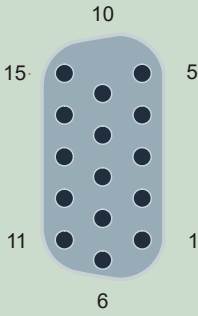
P-VGA (Option)		
	1	RED
	2	GREEN
	3	BLUE
	4	NC
	5	GND
	6	GND
	7	GND
	8	GND
	9	DDC_POV <sup>1)</sup>
	10	GND
	11	NC
	12	VGA_DDC_SDA
	13	HSYNC
	14	VSYSN
	15	VGA_DDC_SCL

<sup>1)</sup> +3.3V protected by a self resetting PolySwitch fuse 0.75A. This voltage is switched on in S0 state only.



## USB Connectors

The Intel® QM87 Platform Controller Hub incorporates a four-port USB 3.0 xHCI host controller. Two ports are directly available on the SC2-PRESTO front panel (type A receptacle), for attachment of external USB devices.

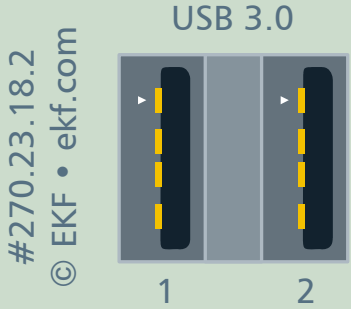
P-USB • Dual USB 3.0 Receptacle		
USB 3.0 dual type A receptacle, stacked, 18-position		
	1	VBUS +5V, 1.5A max <sup>1)</sup>
	2	USB D-
	3	USB D+
	4	GND
	5	SS RX-
	6	SS RX+
	7	GND
	8	SS TX-
	9	SS TX+

<sup>1)</sup> +5V via 1.5A current-limited electronic power switch. Power rail may be switched off by software independently for each port.

Another two USB 3.0 connectors would be available when the SC2-PRESTO is combined with the SCS-TRUMPET mezzanine side card. EKF offers USB cable connector retainer solutions, for rugged applications (picture below).

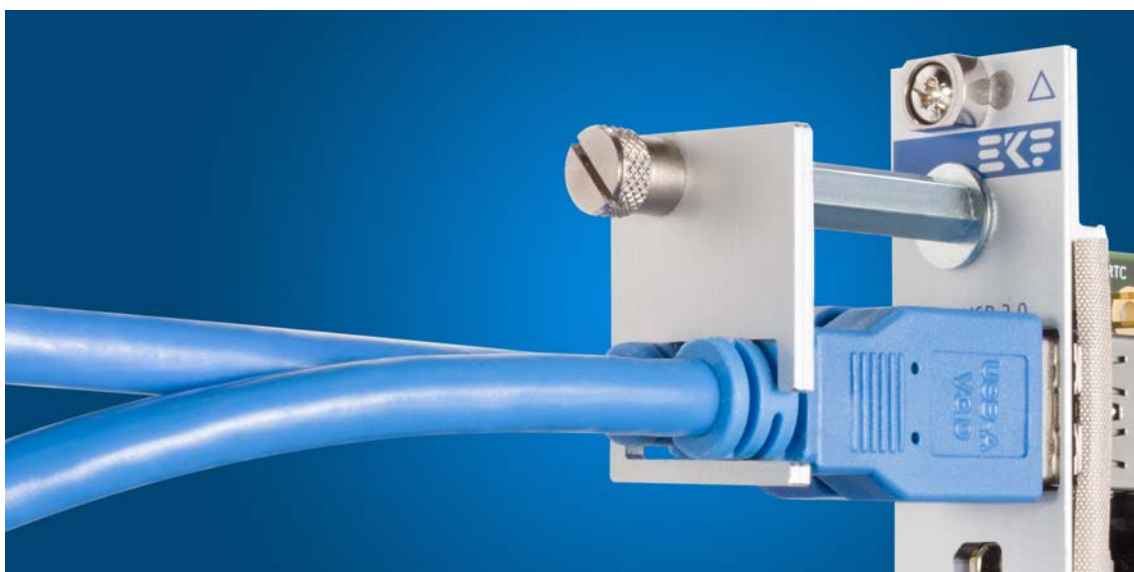

## Ethernet Connectors

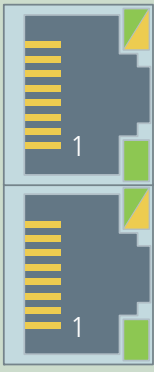
Gigabit Ethernet Ports 1/2 (P-ETH, RJ-45)			
 <p>270.02.08.5</p>	Port 1	1	NC1_MDX0+
		2	NC1_MDX0-
		3	NC1_MDX1+
		4	NC1_MDX2+
		5	NC1_MDX2-
		6	NC1_MDX1-
		7	NC1_MDX3+
		8	NC1_MDX3-
	Port 2	1	NC2_MDX0+
		2	NC2_MDX0-
		3	NC2_MDX1+
		4	NC2_MDX2+
		5	NC2_MDX2-
		6	NC2_MDX1-
		7	NC2_MDX3+
		8	NC2_MDX3-

The lower green LED indicates LINK established when continuously on, and data transfer (activity) when blinking. If the lower green LED is permanently off, no LINK is established. The upper green/yellow dual-LED signals the link speed 1Gbit/s when lit yellow, 100Mbit/s when lit green, and 10Mbit/s when off.

## Mezzanine Connectors



Mezzanine Side Card Connector Suite

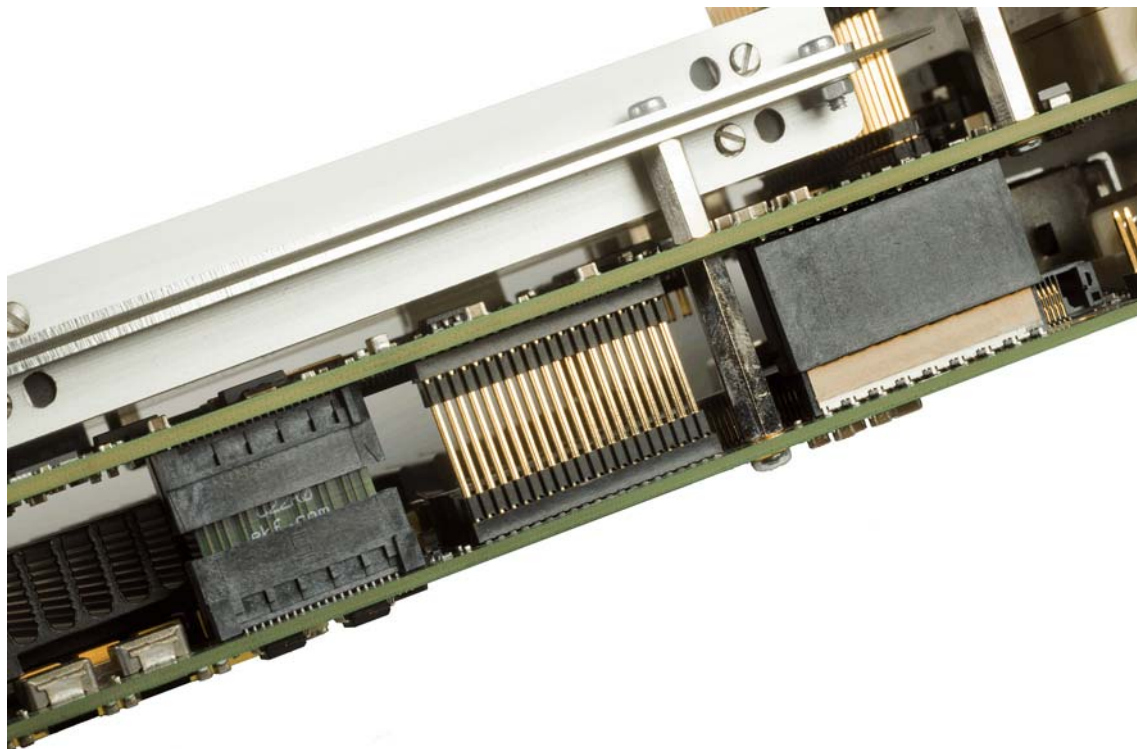

PCIE EXP HSE

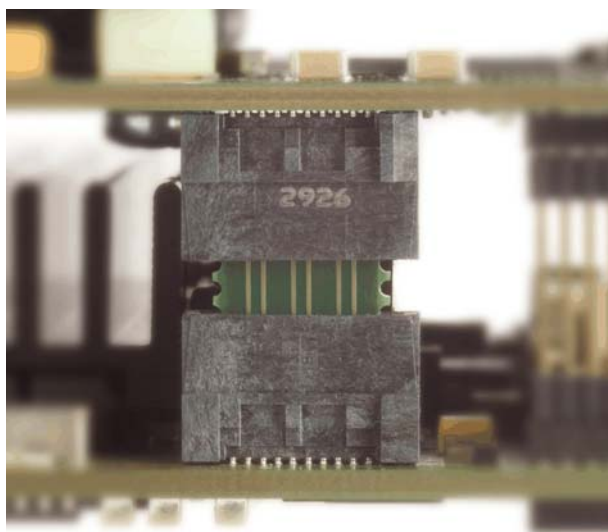

DP

## Expansion Interface P-EXP

P-EXP				
	GND	1	2	+3.3V <sup>1)</sup>
	PCI_CLK (33MHz)	3	4	RST_PLC#
	LPC_AD0	5	6	LPC_AD1
	LPC_AD2	7	8	LPC_AD3
	LPC_FRM#	9	10	LPC_DRQ#
	GND	11	12	+3.3V <sup>1)</sup>
	LPC_SERIRQ	13	14	WAKE#
	EXP_SMI#	15	16	SIO_CLK (14.3MHz)
	FWH_ID0	17	18	FWH_INIT#
	KBRST#	19	20	A20GATE
	GND	21	22	+5V <sup>1)</sup>
	USB_EXP2-	23	24	USB_EXP1-
	USB_EXP2+	25	26	USB_EXP1+
	USB_EXP_OC#	27	28	DBRESET#
	EXP_SCL <sup>2)</sup>	29	30	EXP_SDA <sup>2)</sup>
	GND	31	32	+5V <sup>1)</sup>
	HDA_SDOUT	33	34	HDA_SDIN0
	HDA_RST#CL_RST# <sup>3)</sup>	35	36	HDA_SYNC
	HDA_CLK/CL_CLK <sup>3)</sup>	37	38	HDA_SDIN1/CL_DATA <sup>3)</sup>
	SPEAKER	39	40	+12V <sup>4)</sup>

- 1) Power rail switched on in state S0 only.
- 2) Connected to SMBus via buffered switch, isolated after reset.
- 3) Stuffing option, default is the HDA option.
- 4) Power rail switch off in state S5.

**WARNING:** The +3.3V, +5V and +12V power pins are not protected against a short circuit event. The connector P-EXP therefore should be used only for attachment of an approved expansion side card. The maximum current flow across these pins should be limited to 1A per power pin.

## High Speed Expansion Connector P-HSE

High Speed Expansion P-HSE				
	GND	a1	b1	GND
	SATA_HSE1_TXP	a2	b2	SATA_HSE3_TXP <sup>6)</sup>
	SATA_HSE1_TXN	a3	b3	SATA_HSE3_TXN <sup>6)</sup>
	GND	a4	b4	GND
	SATA_HSE1_RXN	a5	b5	SATA_HSE3_RXN <sup>6)</sup>
	SATA_HSE1_RXP	a6	b6	SATA_HSE3_RXP <sup>6)</sup>
	GND	a7	b7	GND
	SATA_HSE2_TXP	a8	b8	SATA_HSE4_TXP <sup>4)</sup>
	SATA_HSE2_TXN	a9	b9	SATA_HSE4_TXN <sup>4)</sup>
	GND	a10	b10	GND
	SATA_HSE2_RXN	a11	b11	SATA_HSE4_RXN <sup>4)</sup>
	SATA_HSE2_RXP	a12	b12	SATA_HSE4_RXP <sup>4)</sup>
	GND	a13	b13	GND
	USB_HSE1_P	a14	b14	USB_HSE3_P
	USB_HSE1_N	a15	b15	USB_HSE3_N
	GND	a16	b16	GND
	USB_HSE2_P	a17	b17	USB_HSE4_P
	USB_HSE2_N	a18	b18	USB_HSE4_N
	GND	a19	b19	GND
	USB_HSE_OC1#	a20	b20	USB_HSE_OC34#
	USB_HSE_OC2#	a21	b21	USB_HSE_OC34#
	+3.3VS <sup>1)</sup>	a22	b22	+5VS <sup>1)</sup>
	+3.3VS <sup>1)</sup>	a23	b23	+5VS <sup>1)</sup>
	+3.3VA <sup>2)</sup>	a24	b24	+5VA <sup>2)</sup>
	+12V <sup>3)</sup>	a25	b25	+12V <sup>3)</sup>

- <sup>1)</sup> Power rail switched on in state S0 only (Switched).
- <sup>2)</sup> Power rail on with system stand-by power (Always).
- <sup>3)</sup> Power rail switch off in state S5.
- <sup>4)</sup> This SATA channel is not connected on SC2-PRESTO.
- <sup>5)</sup> All SATA channels are derived from the PCH QM87.
- <sup>6)</sup> This SATA channel is limited to max. 3Gbps.
- <sup>7)</sup> All TX/RX designations with respect to the SATA controller.

**WARNING:** The +3.3V, +5V and +12V power pins are not protected against a short circuit event. The connector P-HSE therefore should be used only for attachment of an approved expansion side card. The maximum current flow through these power pins should be limited to 0.5A per pin.



C47-MSATA Mezzanine Storage Module Based on the Connector HSE





SC2-PRESTO w. C48-M2 Mezzanine SATA SSD Module



C48-M2 Mezzanine Storage Module Based on the Connector HSE

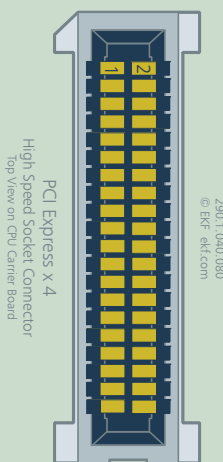

## PCI Express® Expansion Header P-PCIE

P-PCIE				
	GND	1	2	GND
	+5V <sup>1)</sup>	3	4	+3.3V <sup>1)</sup>
	+5V <sup>1)</sup>	5	6	+3.3V <sup>1)</sup>
	GND	7	8	GND
	PE_CLKP	9	10	PLTRST#
	PE_CLKN	11	12	PE_WAKE#
	GND	13	14	GND
	PE_1TP	15	16	PE_1RP
	PE_1TN	17	18	PE_1RN
	GND	19	20	GND
	GND	21	22	GND
	PE_2TP	23	24	PE_2RP
	PE_2TN	25	26	PE_2RN
	GND	27	28	GND
	PE_3TP	29	30	PE_3RP
	PE_3TN	31	32	PE_3RN
	GND	33	34	GND
	PE_4TP	35	36	PE_4RP
	PE_4TN	37	38	PE_4RN
	GND	39	40	GND

<sup>1)</sup> Power rail switched on in state S0 only.

**WARNING:** The +3.3V and +5V power pins are not protected against a short circuit event. The connector P-PCIE therefore should be used only for attachment of an approved expansion side card. The maximum current flow through these power pins should be limited to 1A per pin.

## DisplayPort Expansion Header P-DP3

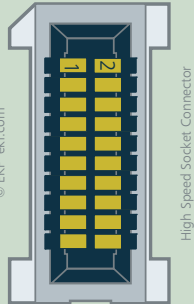
P-DP3				
	GND	1	2	GND
	DP_LANE0+	3	4	DP_LANE3+
	DP_LANE0-	5	6	DP_LANE3-
	GND	7	8	GND
	DP_LANE1+	9	10	DP_AUX+
	DP_LANE1-	11	12	DP_AUX-
	GND	13	14	GND
	DP_LANE2+	15	16	DP_HPD
	DP_LANE2-	17	18	DP_CFG1
	GND	19	20	GND

## Pin Headers & Debug

### Front Panel Handle Microswitch Header P-FPH

The jumper P-FPH is used for attachment of an external SPDT switch. By default, P-FPH is connected across a short cable harness to a microswitch, which is integrated into the SC2-PRESTO front panel handle (ejector lever). The switch performs a power button event (e.g. system shutdown) by short-circuiting the pins 1 and 3 of P-FPH when activated (hold unlock button of front panel handle depressed momentarily).

P-FPH		
# 276.02.003.11 © EKF • ekf.com		
		
1	black	Microswitch Pole (Common), Wired to PLD
2	red	Microswitch Throw - F/P Handle Locked Position, NC
3	yellow	Microswitch Throw - F/P Handle Unlocked Position, Wired to GND

### PLD Programming Header P-ISP

The SC2-PRESTO is provided with a powerful PLD (in-System Programmable Logic Device) which replaces legacy glue logic. The programming header P-ISP is not stuffed (in use for manufacturing only). Its footprint is situated at the bottom side of the board.

P-ISP	
240.1.08.1 • © EKF • ekf.com	
	
1	+3.3V
2	TDO
3	TDI
4	NC
5	KEY
6	TMS
7	GND
8	TCK

## Processor Debug Header P-XDP

The SC2-PRESTO may be equipped with a 26-position processor debug header for hard- and software debugging (specified by Intel® as XDP-SFF-26 Pin Platform Connection). The connector is suitable for installation of a flat flex cable (FFC), in order to attach an JTAG debugger (emulator) such as the Arium ECM-XDP3. An adapter (ITP-XDP-SFF-26) is required in addition to convert the 26-pin XDP-SFF-26 Pin connector to the standard 60-pin XDP.

The header P-XDP would be mounted on the PCB bottom side, but is not stuffed by default.

P-XDP Processor Debug Connector			
269.1.026.902 • FFC Connector			
			
© EKF • ekf.com			
1	OBSFN_A0 (PREQ#)	OBSFN_A1 (PRDY#)	2
3	GND	<i>OBSDATA_A0</i>	4
5	<i>OBSDATA_A1</i>	GND	6
7	<i>OBSDATA_A2</i>	OBSDATA_A3 (CPU_CFG3)	8
9	GND	HOOK0 (CPU_PWRGOOD)	10
11	HOOK1 (XDP_PWRBTN)	HOOK2 (PWR_DBG#)	12
13	HOOK3 (SYS_PWROK)	<i>HOOK4</i>	14
15	<i>HOOK5</i>	VCCOBS_AB (VCCIO_CPU)	16
17	HOOK6 (PLTRST#)	HOOK7 (DBRESET#)	18
19	GND	TDO	20
21	TRST#	TDI	22
23	TMS	<i>TCK1</i>	24
25	GND	TCK0 (TCK)	26

## Backplane Connectors

Six high speed backplane connectors optimized for differential signal transmission are specified as P1 to P6 by the PICMG® CompactPCI® Serial. The mandatory P1 conveys amongst others the power, system control and status pins.

## CompactPCI® Serial Backplane Connector P1

P1 CompactPCI® Serial System Slot Backplane Connector • EKF Part #250.3.1206.20.02 72 pos. 12x6, 14mm Width, Type A												
P1	A	B	C	D	E	F	G	H	I	J	K	L
6	GND	1_PE_TX02+	1_PE_TX02-	GND	1_PE_RX02+	1_PE_RX02-	GND	1_PE_TX03+	1_PE_TX03-	GND	1_PE_RX03+	1_PE_RX03-
5	1_PE_TX00+ <sup>3)</sup>	1_PE_TX00- <sup>3)</sup>	GND	1_PE_RX00+	1_PE_RX00-	GND	1_PE_TX01+	1_PE_TX01-	GND	1_PE_RX01+	1_PE_RX01-	GND
4	GND	1_USB2+	1_USB2-	GND	reserved <sup>1)</sup>	reserved <sup>1)</sup>	GND	1_SATA_TX+ <sup>2)</sup>	1_SATA_TX- <sup>2)</sup>	GND	1_SATA_RX+ <sup>2)</sup>	1_SATA_RX- <sup>2)</sup>
3	1_USB3_TX+	1_USB3_TX-	PWRBTN#	1_USB3_RX+	1_USB3_RX-	PWR_FAIL#	SATA_SDI <sup>1) 6)</sup>	SATA_SDO <sup>5) 6)</sup>	GA2 <sup>1)</sup>	SATA_SCL <sup>4) 6)</sup>	SATA_SL <sup>6)</sup>	GA3 <sup>1)</sup>
2	GND	I <sup>2</sup> C_SCL	I <sup>2</sup> C_SDA	GND	PS_ON#	RST#	GND	PRST#	WAKE_IN#	GND	reserved <sup>1)</sup>	SYSEN#
1	+12V	+5V STANDBY	GND	+12V	+12V	GND	+12V	+12V	GND	+12V	+12V	GND

<sup>1)</sup> Not connected.

<sup>2)</sup> Not connected (according the CompactPCI® Serial Precedence Order Rules).

<sup>3)</sup> Polarity inversion was made on these lanes on SC2-PRESTO for better routing. This is allowed according the "PCI Express Base Specification 3.0" and has no effect on function or performance of the link. The pin-out shown is as per specification.

<sup>4)</sup> This pin may carry the IEEE 1588 Pulse per Second (PPS) signal when enabled within UEFI BIOS settings.

<sup>5)</sup> This pin may carry the IEEE 1588 Pulse per Minute (PPM) signal when enabled within UEFI BIOS settings.

<sup>6)</sup> 10kΩ Pull-Up resistor to +3.3V when inserted in system controller slot.

## CompactPCI® Serial Backplane Connector P2

P2 CompactPCI® Serial System Slot Backplane Connector • EKF Part #250.3.1208.20.00 96 pos. 12x8, 16mm Width, Type B												
P2	A	B	C	D	E	F	G	H	I	J	K	L
8	GND	IO <sup>1)</sup>	IO <sup>1)</sup>	GND	2_USB2+	2_USB2-	GND	3_USB2+	3_USB2-	IO <sup>1)</sup>	4_USB2+	4_USB2-
7	IO <sup>1)</sup>	IO <sup>1)</sup>	GND	IO <sup>1)</sup>	IO <sup>1)</sup>	GND	IO <sup>1)</sup>	IO <sup>1)</sup>	GND	IO <sup>1)</sup>	IO <sup>1)</sup>	GND
6	GND	2_PE_TX06+	2_PE_TX06-	GND	2_PE_RX06+ <sup>3)</sup>	2_PE_RX06- <sup>3)</sup>	GND	2_PE_TX07+	2_PE_TX07-	GND	2_PE_RX07+ <sup>3)</sup>	2_PE_RX07- <sup>3)</sup>
5	2_PE_TX04+ <sup>3)</sup>	2_PE_TX04- <sup>3)</sup>	GND	2_PE_RX04+ <sup>3)</sup>	2_PE_RX04- <sup>3)</sup>	GND	2_PE_TX05+ <sup>3)</sup>	2_PE_TX05- <sup>3)</sup>	GND	2_PE_RX05+	2_PE_RX05-	GND
4	GND	2_PE_TX02+	2_PE_TX02-	GND	2_PE_RX02+ <sup>3)</sup>	2_PE_RX02- <sup>3)</sup>	GND	2_PE_TX03+	2_PE_TX03-	GND	2_PE_RX03+	2_PE_RX03-
3	2_PE_TX00+	2_PE_TX00-	GND	2_PE_RX00+	2_PE_RX00-	GND	2_PE_TX01+	2_PE_TX01-	GND	2_PE_RX01+	2_PE_RX01-	GND
2	GND	1_PE_TX06+ <sup>3)</sup>	1_PE_TX06- <sup>3)</sup>	GND	1_PE_RX06+	1_PE_RX06-	GND	1_PE_TX07+ <sup>3)</sup>	1_PE_TX07- <sup>3)</sup>	GND	1_PE_RX07+	1_PE_RX07-
1	1_PE_TX04+	1_PE_TX04-	GND	1_PE_RX04+	1_PE_RX04-	GND	1_PE_TX05+	1_PE_TX05-	GND	1_PE_RX05+	1_PE_RX05-	GND

<sup>1)</sup> Not connected.

<sup>2)</sup> The PCI Express Lanes 1\_PE\_\* and 2\_PE\_\* are derived from the Core™ processor and capable to transfer 8GT/s.

<sup>3)</sup> Polarity inversion was made on these lanes on SC2-PRESTO for better routing. This is allowed according the "PCI Express Base Specification 3.0" and has no effect on function or performance of the link. The pin-out shown is as per specification.

## CompactPCI® Serial Backplane Connector P3

P3 CompactPCI® Serial System Slot Backplane Connector • EKF Part #250.3.1208.20.00 96 pos. 12x8, 16mm Width, Type B												
P3	A	B	C	D	E	F	G	H	I	J	K	L
8	GND	7_SATA_TX+ <sup>2)</sup>	7_SATA_TX- <sup>2)</sup>	GND	7_SATA_RX+ <sup>2)</sup>	7_SATA_RX- <sup>2)</sup>	GND	8_SATA_TX+ <sup>2)</sup>	8_SATA_TX- <sup>2)</sup>	GND	8_SATA_RX+ <sup>2)</sup>	8_SATA_RX- <sup>2)</sup>
7	5_SATA_TX+ <sup>4)</sup>	5_SATA_TX- <sup>4)</sup>	GND	5_SATA_RX+ <sup>4)</sup>	5_SATA_RX- <sup>4)</sup>	GND	6_SATA_TX+ <sup>4)</sup>	6_SATA_TX- <sup>4)</sup>	GND	6_SATA_RX+ <sup>4)</sup>	6_SATA_RX- <sup>4)</sup>	GND
6	GND	3_SATA_TX+ <sup>4)</sup>	3_SATA_TX- <sup>4)</sup>	GND	3_SATA_RX+ <sup>4)</sup>	3_SATA_RX- <sup>4)</sup>	GND	4_SATA_TX+ <sup>4)</sup>	4_SATA_TX- <sup>4)</sup>	GND	4_SATA_RX+ <sup>4)</sup>	4_SATA_RX- <sup>4)</sup>
5	8_USB3_TX+ <sup>1)</sup>	8_USB3_TX- <sup>1)</sup>	GND	8_USB3_RX+ <sup>1)</sup>	8_USB3_RX- <sup>1)</sup>	GND	2_SATA_TX+ <sup>3)</sup>	2_SATA_TX- <sup>3)</sup>	GND	2_SATA_RX+ <sup>3)</sup>	2_SATA_RX- <sup>3)</sup>	GND
4	GND	6_USB3_TX+ <sup>1)</sup>	6_USB3_TX- <sup>1)</sup>	GND	6_USB3_RX+ <sup>1)</sup>	6_USB3_RX- <sup>1)</sup>	GND	7_USB3_TX+ <sup>1)</sup>	7_USB3_TX- <sup>1)</sup>	GND	7_USB3_RX+ <sup>1)</sup>	7_USB3_RX- <sup>1)</sup>
3	4_USB3_TX+ <sup>1)</sup>	4_USB3_TX- <sup>1)</sup>	GND	4_USB3_RX+ <sup>1)</sup>	4_USB3_RX- <sup>1)</sup>	GND	5_USB3_TX+ <sup>1)</sup>	5_USB3_TX- <sup>1)</sup>	GND	5_USB3_RX+ <sup>1)</sup>	5_USB3_RX- <sup>1)</sup>	GND
2	GND	2_USB3_TX+ <sup>1)</sup>	2_USB3_TX- <sup>1)</sup>	GND	2_USB3_RX+ <sup>1)</sup>	2_USB3_RX- <sup>1)</sup>	GND	3_USB3_TX+ <sup>1)</sup>	3_USB3_TX- <sup>1)</sup>	GND	3_USB3_RX+ <sup>1)</sup>	3_USB3_RX- <sup>1)</sup>
1	5_USB2+ <sup>1)</sup>	5_USB2- <sup>1)</sup>	GND	6_USB2+ <sup>1)</sup>	6_USB2- <sup>1)</sup>	GND	7_USB2+ <sup>1)</sup>	7_USB2- <sup>1)</sup>	GND	8_USB2+ <sup>1)</sup>	8_USB2- <sup>1)</sup>	GND

- <sup>1)</sup> Not connected (according the CompactPCI® Serial Precedence Order Rules).
- <sup>2)</sup> This SATA channel is derived from the PCH QM87, capable of up to 6Gbps.
- <sup>3)</sup> This SATA channel is derived from the PCH QM87, capable of up to 3Gbps.
- <sup>4)</sup> This SATA channel is derived from the 88SE9230 SATA Host Controller.
- <sup>5)</sup> The SATA channel assignment shown is valid from Rev. 1+ of the board.



## CompactPCI® Serial Backplane Connector P4

P4 CompactPCI® Serial System Slot Backplane Connector • EKF Part #250.3.1208.20.00 96 pos. 12x8, 16mm Width, Type B												
P4	A	B	C	D	E	F	G	H	I	J	K	L
8	GND	6_PE_TX02+ <sup>1)</sup>	6_PE_TX02- <sup>1)</sup>	GND	6_PE_RX02+ <sup>1)</sup>	6_PE_RX02- <sup>1)</sup>	GND	6_PE_TX03+ <sup>1)</sup>	6_PE_TX03- <sup>1)</sup>	GND	6_PE_RX03+ <sup>1)</sup>	6_PE_RX03- <sup>1)</sup>
7	6_PE_TX00+	6_PE_TX00-	GND	6_PE_RX00+	6_PE_RX00-	GND	6_PE_TX01+ <sup>1)</sup>	6_PE_TX01- <sup>1)</sup>	GND	6_PE_RX01+ <sup>1)</sup>	6_PE_RX01- <sup>1)</sup>	GND
6	GND	5_PE_TX02+ <sup>1)</sup>	5_PE_TX02- <sup>1)</sup>	GND	5_PE_RX02+ <sup>1)</sup>	5_PE_RX02- <sup>1)</sup>	GND	5_PE_TX03+ <sup>1)</sup>	5_PE_TX03- <sup>1)</sup>	GND	5_PE_RX03+ <sup>1)</sup>	5_PE_RX03- <sup>1)</sup>
5	5_PE_TX00+	5_PE_TX00-	GND	5_PE_RX00+	5_PE_RX00-	GND	5_PE_TX01+ <sup>1)</sup>	5_PE_TX01- <sup>1)</sup>	GND	5_PE_RX01+ <sup>1)</sup>	5_PE_RX01- <sup>1)</sup>	GND
4	GND	4_PE_TX02+ <sup>1)</sup>	4_PE_TX02- <sup>1)</sup>	GND	4_PE_RX02+ <sup>1)</sup>	4_PE_RX02- <sup>1)</sup>	GND	4_PE_TX03+ <sup>1)</sup>	4_PE_TX03- <sup>1)</sup>	GND	4_PE_RX03+ <sup>1)</sup>	4_PE_RX03- <sup>1)</sup>
3	4_PE_TX00+	4_PE_TX00-	GND	4_PE_RX00+	4_PE_RX00-	GND	4_PE_TX01+ <sup>1)</sup>	4_PE_TX01- <sup>1)</sup>	GND	4_PE_RX01+ <sup>1)</sup>	4_PE_RX01- <sup>1)</sup>	GND
2	GND	3_PE_TX02+ <sup>1)</sup>	3_PE_TX02- <sup>1)</sup>	GND	3_PE_RX02+ <sup>1)</sup>	3_PE_RX02- <sup>1)</sup>	GND	3_PE_TX03+ <sup>1)</sup>	3_PE_TX03- <sup>1)</sup>	GND	3_PE_RX03+ <sup>1)</sup>	3_PE_RX03- <sup>1)</sup>
1	3_PE_TX00+	3_PE_TX00-	GND	3_PE_RX00+	3_PE_RX00-	GND	3_PE_TX01+ <sup>1)</sup>	3_PE_TX01- <sup>1)</sup>	GND	3_PE_RX01+ <sup>1)</sup>	3_PE_RX01- <sup>1)</sup>	GND

<sup>1)</sup> Not connected.

## CompactPCI® Serial Backplane Connector P5

P5 CompactPCI® Serial System Slot Backplane Connector • EKF Part #250.3.1206.20.00 72 pos. 12x6, 12mm Width, Type C												
P5	A	B	C	D	E	F	G	H	I	J	K	L
6	5_PE_CLKE#	5_PE_CLK+	5_PE_CLK-	6_PE_CLKE#	6_PE_CLK+	6_PE_CLK-	7_PE_CLKE#	7_PE_CLK+	7_PE_CLK-	8_PE_CLKE#	8_PE_CLK+	8_PE_CLK-
5	1_PE_CLK+	1_PE_CLK-	1_PE_CLKE#	2_PE_CLK+	2_PE_CLK-	2_PE_CLKE#	3_PE_CLK+	3_PE_CLK-	3_PE_CLKE#	4_PE_CLK+	4_PE_CLK-	4_PE_CLKE#
4	GND	8_PE_TX02+ <sup>1)</sup>	8_PE_TX02- <sup>1)</sup>	GND	8_PE_RX02+ <sup>1)</sup>	8_PE_RX02- <sup>1)</sup>	GND	8_PE_TX03+ <sup>1)</sup>	8_PE_TX03- <sup>1)</sup>	GND	8_PE_RX03+ <sup>1)</sup>	8_PE_RX03- <sup>1)</sup>
3	8_PE_TX00+	8_PE_TX00-	GND	8_PE_RX00+	8_PE_RX00-	GND	8_PE_TX01+ <sup>1)</sup>	8_PE_TX01- <sup>1)</sup>	GND	8_PE_RX01+ <sup>1)</sup>	8_PE_RX01- <sup>1)</sup>	GND
2	GND	7_PE_TX02+ <sup>1)</sup>	7_PE_TX02- <sup>1)</sup>	GND	7_PE_RX02+ <sup>1)</sup>	7_PE_RX02- <sup>1)</sup>	GND	7_PE_TX03+ <sup>1)</sup>	7_PE_TX03- <sup>1)</sup>	GND	7_PE_RX03+ <sup>1)</sup>	7_PE_RX03- <sup>1)</sup>
1	7_PE_TX00+	7_PE_TX00-	GND	7_PE_RX00+	7_PE_RX00-	GND	7_PE_TX01+ <sup>1)</sup>	7_PE_TX01- <sup>1)</sup>	GND	7_PE_RX01+ <sup>1)</sup>	7_PE_RX01- <sup>1)</sup>	GND

<sup>1)</sup> Not connected.

## CompactPCI® Serial Backplane Connector P6

P6 CompactPCI® Serial System Slot Backplane Connector • EKF Part #250.3.1208.20.02 96 pos. 12x8, 18mm Width, Type D												
P6	A	B	C	D	E	F	G	H	I	J	K	L
8	GND	8_ETH_A+ <sup>1)</sup>	8_ETH_A- <sup>1)</sup>	GND	8_ETH_B+ <sup>1)</sup>	8_ETH_B- <sup>1)</sup>	GND	8_ETH_C+ <sup>1)</sup>	8_ETH_C- <sup>1)</sup>	GND	8_ETH_D+ <sup>1)</sup>	8_ETH_D- <sup>1)</sup>
7	7_ETH_A+ <sup>1)</sup>	7_ETH_A- <sup>1)</sup>	GND	7_ETH_B+ <sup>1)</sup>	7_ETH_B- <sup>1)</sup>	GND	7_ETH_C+ <sup>1)</sup>	7_ETH_C- <sup>1)</sup>	GND	7_ETH_D+ <sup>1)</sup>	7_ETH_D- <sup>1)</sup>	GND
6	GND	6_ETH_A+ <sup>1)</sup>	6_ETH_A- <sup>1)</sup>	GND	6_ETH_B+ <sup>1)</sup>	6_ETH_B- <sup>1)</sup>	GND	6_ETH_C+ <sup>1)</sup>	6_ETH_C- <sup>1)</sup>	GND	6_ETH_D+ <sup>1)</sup>	6_ETH_D- <sup>1)</sup>
5	5_ETH_A+ <sup>1)</sup>	5_ETH_A- <sup>1)</sup>	GND	5_ETH_B+ <sup>1)</sup>	5_ETH_B- <sup>1)</sup>	GND	5_ETH_C+ <sup>1)</sup>	5_ETH_C- <sup>1)</sup>	GND	5_ETH_D+ <sup>1)</sup>	5_ETH_D- <sup>1)</sup>	GND
4	GND	4_ETH_A+ <sup>1)</sup>	4_ETH_A- <sup>1)</sup>	GND	4_ETH_B+ <sup>1)</sup>	4_ETH_B- <sup>1)</sup>	GND	4_ETH_C+ <sup>1)</sup>	4_ETH_C- <sup>1)</sup>	GND	4_ETH_D+ <sup>1)</sup>	4_ETH_D- <sup>1)</sup>
3	3_ETH_A+ <sup>1)</sup>	3_ETH_A- <sup>1)</sup>	GND	3_ETH_B+ <sup>1)</sup>	3_ETH_B- <sup>1)</sup>	GND	3_ETH_C+ <sup>1)</sup>	3_ETH_C- <sup>1)</sup>	GND	3_ETH_D+ <sup>1)</sup>	3_ETH_D- <sup>1)</sup>	GND
2	GND	2_ETH_A+	2_ETH_A-	GND	2_ETH_B+	2_ETH_B-	GND	2_ETH_C+	2_ETH_C-	GND	2_ETH_D+	2_ETH_D-
1	1_ETH_A+	1_ETH_A-	GND	1_ETH_B+	1_ETH_B-	GND	1_ETH_C+	1_ETH_C-	GND	1_ETH_D+	1_ETH_D-	GND

<sup>1)</sup> Not connected (according the CompactPCI® Serial Precedence Order Rules).

## Appendix

## Known Issues

Known Issues		
Date	Issue	Description
2015-07-02	3	Some Mouse Devices may lead to a lock of the front USB Interfaces. This will inhibit the boot of an OS located on one of the USB Interfaces.  <u>Workaround:</u> Change UEFI/BIOS setting of node „Advanced/USB Configuration/xHCI Mode“ from „Auto“ to „Disabled“.
	Fix	There are no plans to fix this erratum.
2015-07-02	7	Sound via P-EXP Interface does not work because of missing UEFI/BIOS support (Build #194).
	Fix	Fixed with UEFI/BIOS Build #208.
2015-07-02	8	On the CPCI Serial Fat Pipe Slots 1/2 PCI Express Generation 3 Speed may not work properly. When possible reduce the speed to 5GT/s. Running a link with 8GT/s needs a well tuned system with interface parameters adjusted to the components in use (backplane, periphery board).  <u>Workaround:</u> Change UEFI/BIOS setting of node „Advanced/SA PCI Express Configuration/Select max speed“ from „Auto“ to „Gen2“.
	Fix	Gen2 speed would be implemented as default with UEFI/BIOS Build #204.
2015-07-02	12	SIO functions (e.g. COM ports) on Mezzanine Boards like SCS-TRUMPET do not work because of missing UEFI/BIOS support (Build #194).
	Fix	Will be fixed in a future UEFI/BIOS release.
2016-07-07	13	When power cycling the board for a short time without removing the complete power (i.e. the front LED remain on) the hardware may accidentally report a power fail event that is displayed by UEFI/BIOS. In this case the message may be ignored, it generally should not signal a system failure.
	Fix	There are no plans to fix this issue

## Mechanical Drawing

The following drawing shows the positions of mounting holes and expansion connectors on the SC2-PRESTO.

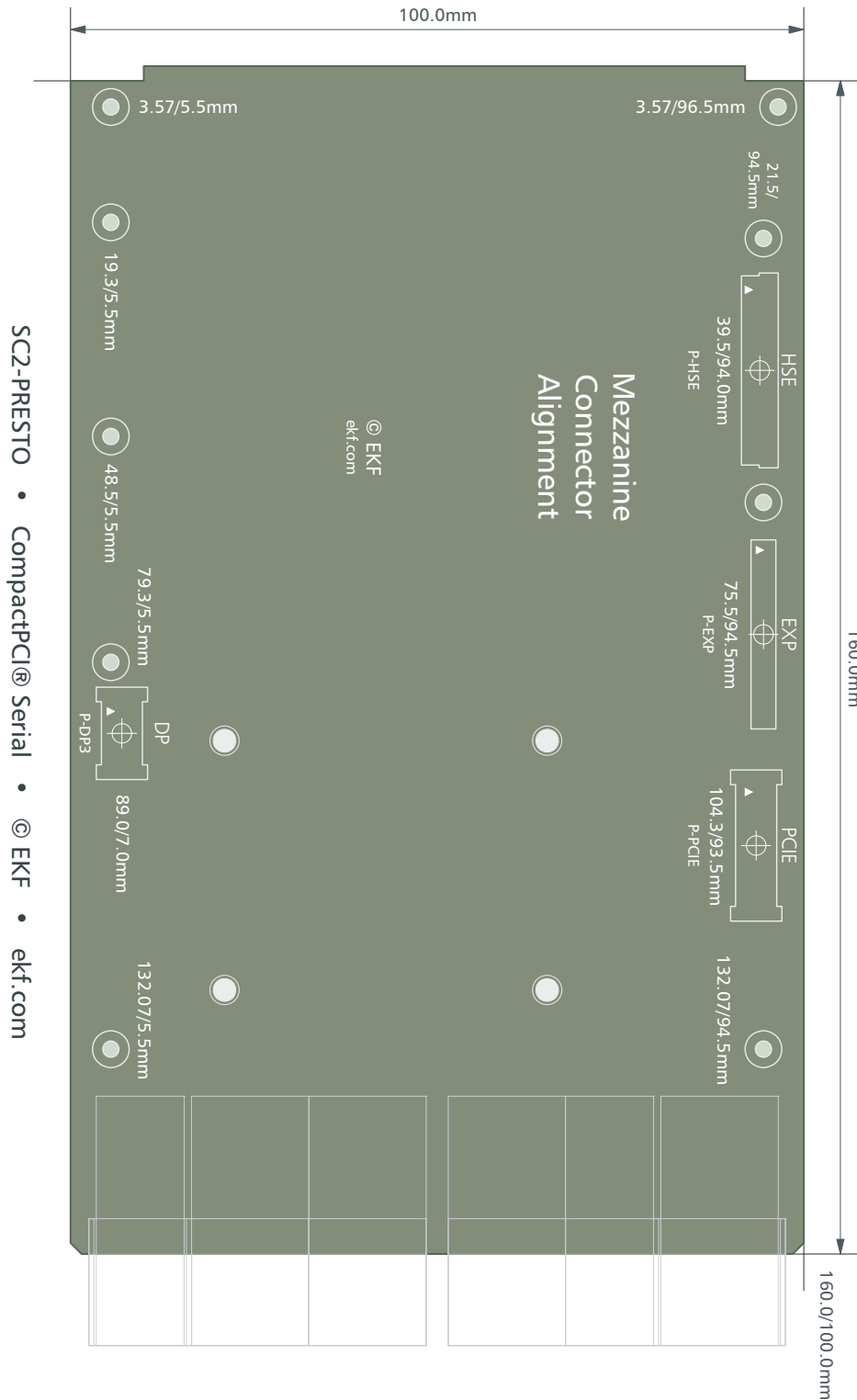

SC2-PRESTO • CompactPCI® Serial • © EKF • ekf.com



Beyond All Limits:  
EKF High Performance Embedded

EKF Elektronik GmbH  
Philipp-Reis-Str. 4 (Haus 1)  
Lilienthalstr. 2 (Haus 2)  
59065 HAMM  
Germany



Phone +49 (0)2381/6890-0  
Fax +49 (0)2381/6890-90  
Internet [www.ekf.com](http://www.ekf.com)  
E-Mail [sales@ekf.com](mailto:sales@ekf.com)